



# Detcon MicroSafe™

## DM-634 Oxygen Deficiency Sensor (0-25% O2)



### Operator's Installation & Instruction Manual

June 18, 2009 • Document #2016T • Version 6.5

# Table of Contents

- 3.0 Description
- 3.1 Principle of Operation
- 3.2 Application
- 3.3 Specifications
- 3.4 Operating Software
- 3.5 Installation
- 3.6 Start-up
- 3.7 Calibration
- 3.8 Status of Programming: Alarms, Calibration Level, RS-485 ID, and Sensor Life
- 3.9 Programming Alarms
- 3.10 Program Features
- 3.11 RS-485 Protocol
- 3.12 Display Contrast Adjust
- 3.12A Trouble Shooting Guide
- 3.13 Spare Parts List
- 3.14 Warranty
- 3.15 Service Policy
- 3.16 Software Flow Chart

### 3.0 DESCRIPTION

Detcon MicroSafe™ Model DM-634, oxygen deficiency sensors are non-intrusive “Smart” sensors designed to detect and monitor O<sub>2</sub> in air over the range of 0-25%. One of the primary features of the sensor is its method of automatic calibration which guides the user through each step via instructions displayed on the backlit LCD. The sensor features field adjustable, fully programmable alarms and provides relays for two alarms plus fault as standard. The sensor comes with two different outputs: analog 4-20 mA, and serial RS-485. These outputs allow for greater flexibility in system integration and installation. The microprocessor supervised electronics are packaged as a plug-in module that mates to a standard connector board. Both are housed in an explosion proof conduit that includes a glass lens window which allows for the display of sensor readings as well as access to the sensor’s menu driven features via a hand-held programming magnet.



#### 3.0.1 Sensor Technology

The sensor technology is of the two electrode, galvanic metal air battery type cell, which is housed as a field replaceable plug-in module. The cell is diffusion limited and functions as a direct current generator proportional to the amount of oxygen adsorption. The sensors are temperature compensated and show good accuracy and stability over the operating temperature range -4° to +122° Fahrenheit. The sensor is warranted for two year and has an expected service life of up to two years in ambient air at 20.9% oxygen

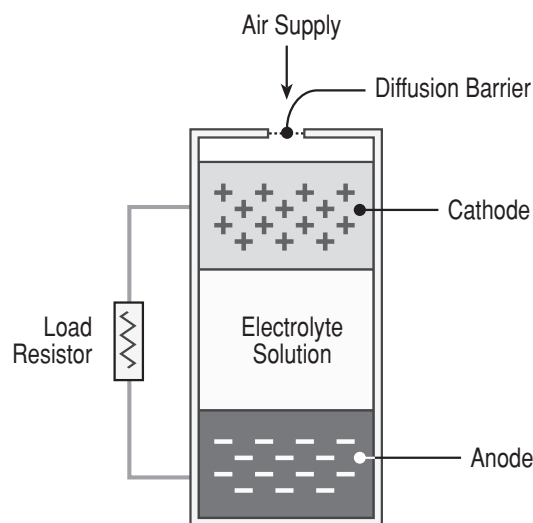

Construction of Galvanic Cell

### 3.0.2 Microprocessor Control Circuit

The control circuit is microprocessor based and is packaged as a plug-in field replaceable module, facilitating easy replacement and minimum down time. Circuit functions include a basic sensor pre-amplifier, on-board power supplies, microprocessor, back lit alpha numeric display, alarm status LED indicators, magnetic programming switches, an RS-485 communication port, and a linear 4-20 mA DC output.

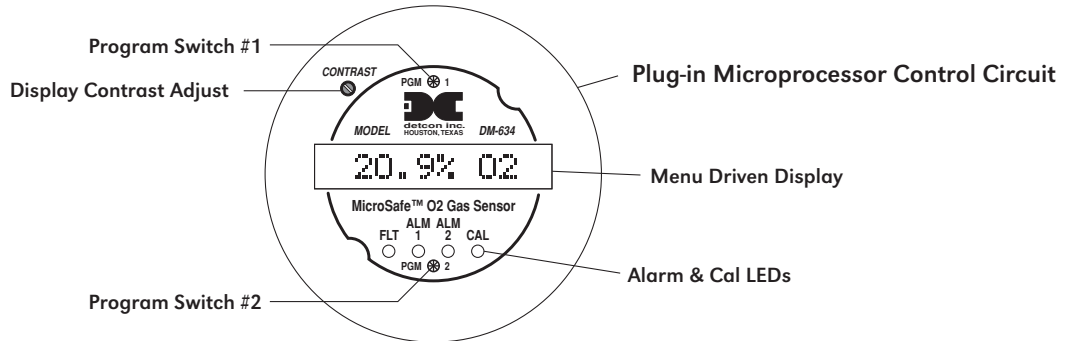

### 3.0.3 Base Connector Board

The base connector board is mounted in the explosion proof enclosure and includes: the mating connector for the control circuit, reverse input and secondary transient suppression, input filter, alarm relays, lugless terminals for all field wiring, and a terminal strip for storing unused programming jumper tabs. The alarm relays are contact rated 5 amps @ 250 VAC, 5 amps @ 30 VDC and coil rated at 24 VDC. Gold plated program jumpers are used to select either the normally open or normally closed relay contacts.

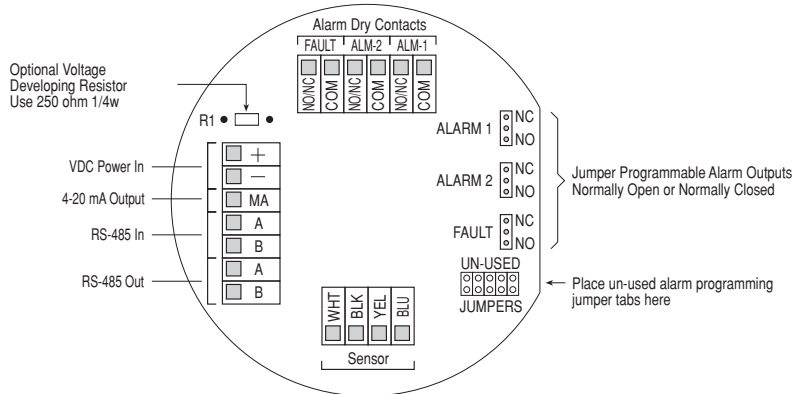

### 3.0.4 Explosion Proof Enclosure

The sensors are packaged in a cast metal explosion proof enclosure. The enclosure is fitted with a threaded cover that has a glass lens window. Magnetic program switches located behind the transmitter module face plate are activated through the lens window via a hand-held magnetic programming tool allowing non-intrusive operator interface with the sensor. All calibration and alarm level adjustments can be accomplished without removing the cover or declassifying the area. Electrical classification is Class I; Groups B, C, D; Div. 1.

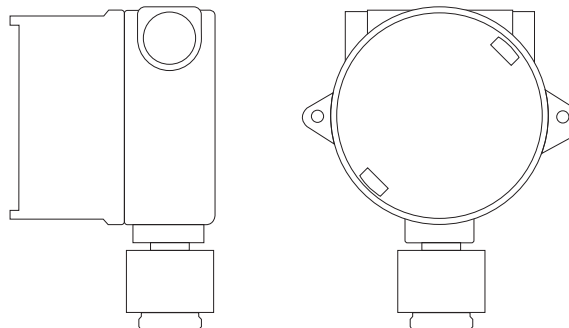

### 3.1 PRINCIPLE OF OPERATION

Method of detection is by a controlled rate of diffusion. Air and gas diffuse through a sintered stainless steel filter and a diffusion barrier. As oxygen is adsorbed into the electrolyte solution a current is generated between the cathode and anode electrodes. This current output rises with increases in oxygen concentration and reverses with lower concentrations. The quick response of the cell results in continuous monitoring of ambient air conditions.

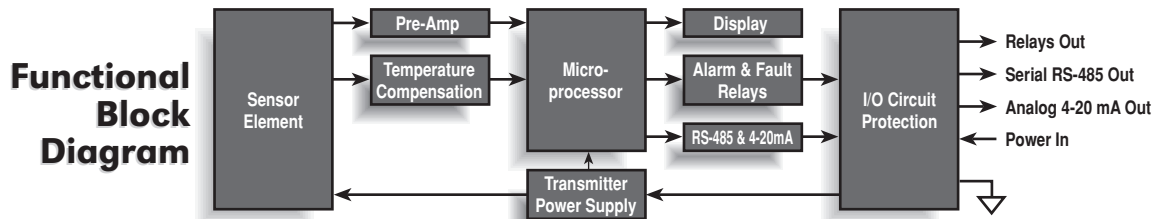

### 3.2 APPLICATION

Model DM-634 MicroSafe™ sensors are designed to detect and monitor oxygen deficiency in ambient air in the range of 0-25%. Minimum sensitivity and scale resolution is 0.1%. Operating temperature range is -4° F. to +122° F. While the sensor is capable of operating outside these temperatures, performance specifications are verified within the limit.

#### 3.2.1 Sensor Placement/Mounting

Sensor location should be reviewed by facility engineering and safety personnel. Area leak sources and perimeter mounting are typically used to determine number and location of sensors. The sensors are generally located 2 - 4 feet above grade.

#### 3.2.2 Interference Data

Methane	100% = 0
Hydrocarbons	100% = 0
Hydrogen	100% = < -2%
Carbon Monoxide	20% = < -0.5%

### 3.3 SPECIFICATIONS

#### Method of Detection

Air battery diffusion/adsorption

#### Electrical Classification

Class I; Groups B, C, D; Div. 1.

#### Response Time (T90)

T90 < 20 seconds

#### Clearing Time

90% < 20 seconds

#### Repeatability

± 2% FS

#### Range

0-25% O<sub>2</sub>

#### Operating Temperature

-4° to +122° F

#### Accuracy

± 2% FS

#### Sensor Warranty

2 year conditional

## Power Consumption

Normal operation = 28 mA (<3/4 watt); Full alarm = 85 mA (2 watts)

## Output

3 relays (alarm 1, alarm 2, and fault) contact rated 5 amps @ 250 VAC, 5 amps @ 30 VDC;  
Linear 4-20 mA DC; RS-485 Modbus™

## Input Voltage

22.5-28 VDC

## 3.4 OPERATING SOFTWARE

Operating software is menu listed with operator interface via the two magnetic program switches located under the face plate. The two switches are referred to as “PGM 1” and “PGM 2”. The menu list consists of 3 items which include sub-menus as indicated below. (Note: see the end of this manual for a complete software flow chart.)

01. Normal Operation
  - a) Current Status
  
02. Calibration Mode
  - a) Span
  
03. Program Menu
  - a) Program Status
  - b) Alarm 1 Level
  - c) Alarm 2 Level
  - d) Set Calibration Level

### 3.4.1 Normal Operation

In normal operation, the display tracks the current status of the sensor and gas concentration and appears as: “**20.9 % O2**”. The mA current output corresponds to the monitoring level of 0-25% O2 = 4-20 mA.

### 3.4.2 Calibration Mode

Calibration mode allows for sensor span adjustments. “**2-SPAN**”

The default span adjustment setting is 20.9% which is the normal atmospheric concentration of O2. Span gas concentrations other than 20.9% may be used. Refer to section 3.4.3.4 for details. “**AUTO SPAN**”

### 3.4.3 Program Mode

The program mode provides a program status menu and allows for the adjustment of alarm set point levels and the programming of the calibration gas level setting.

#### 3.4.3.1 Program Status

The program status scrolls through a menu that displays:

- \* The gas type, range of detection and software version number. The menu item appears as: “**O2 0-25 V528J**”
- \* The alarm set point level of alarm 1. The menu item appears as: “**ALM1 SET @ xx.x%**”
- \* The alarm firing direction of alarm 1. The menu item appears as: “**ALM1 DESCENDING**” or ascending.
- \* The alarm relay latch mode of alarm 1. The menu item appears as: “**ALM1 NONLATCHING**” or latching.
- \* The alarm relay energize state of alarm 1. The menu item appears as: “**ALM1 DE-ENERGIZED**” or energized.
- \* The alarm set point level of alarm 2. The menu item appears as: “**ALM2 SET @ xx.x%**”
- \* The alarm firing direction of alarm 2. The menu item appears as: “**ALM2 DESCENDING**” or ascending.
- \* The alarm relay latch mode of alarm 2. The menu item appears as: “**ALM2 LATCHING**” or nonlatching.
- \* The alarm relay energize state of alarm 2. The menu item appears as: “**ALM2 DE-ENERGIZED**” or energized.
- \* The alarm relay latch mode of the fault alarm. The menu item appears as: “**FLT NONLATCHING**” or latching.
- \* The alarm relay energize state of the fault alarm. The menu item appears as: “**FLT ENERGIZED**” or de-energized.
- \* The calibration gas level setting. The menu item appears as: “**CalLevel @ xx.x%**”
- \* Identification of the RS-485 ID number setting. The menu item appears as: “**485 ID SET @ ##**”

\* The estimated remaining sensor life. The menu item appears as: “**SENSOR LIFE 100%**”

#### 3.4.3.2 Alarm 1 Level Adjustment

The alarm 1 level is adjustable from 2.5% to 22.5%. The menu item appears as: “**SET ALM1 @ 19.5%**”

#### 3.4.3.3 Alarm 2 Level Adjustment

The alarm 2 level is adjustable from 2.5% to 22.5%. The menu item appears as: “**SET ALM2 @ 17.5%**”

#### 3.4.3.4 Calibration Level Adjustment

The calibration level is adjustable from 15.0% to 25.0% O<sub>2</sub>. The menu item appears as: “**CalLevel @ xx.x%**”

## 3.5 INSTALLATION

Optimum performance of ambient air/gas sensor devices is directly relative to proper location and installation practice.

### 3.5.1 Field Wiring Table (4-20 mA output)

Detcon MicroSafe™ O<sub>2</sub> sensor assemblies require three conductor connection between power supplies and host electronic controllers. Wiring designators are **+** (DC), **-** (DC), and **mA** (sensor signal). Maximum single conductor resistance between sensor and controller is 10 ohms. Maximum wire size for termination in the sensor assembly terminal board is 14 gauge.

<b>AWG</b>	<b>Meters</b>	<b>Feet</b>
20	240	800
18	360	1200
16	600	2000
14	900	3000

**Note 1:** This wiring table is based on stranded tinned copper wire and is designed to serve as a reference only.

**Note 2:** Shielded cable may be required in installations where cable trays or conduit runs include high voltage lines or other sources of induced interference.

The RS-485 (if applicable) requires 24 gauge, two conductor, shielded, twisted pair cable between sensor and host PC. Use Belden part number 9841. Two sets of terminals are located on the connector board to facilitate serial loop wiring from sensor to sensor. Wiring designators are **A & B** (IN) and **A & B** (OUT).

### 3.5.2 Sensor Location

Selection of sensor location is critical to the overall safe performance of the product. Five factors play an important role in selection of sensor locations:

- (1) Density of the gas to be detected
- (2) Most probable leak sources within the industrial process
- (3) Ventilation or prevailing wind conditions
- (4) Personnel exposure
- (5) Accessibility for routine maintenance

**Density** - Placement of sensors relative to the density of the target gas is such that sensors for the detection of heavier than air gases should be located within 2-4 feet of grade as these heavy gases will tend to settle in low lying areas. For gases lighter than air, sensor placement should be 4-8 feet above grade in open areas or in pitched areas of enclosed spaces.

**Leak Sources** - Most probable leak sources within an industrial process include flanges, valves, and tubing connections of the sealed type where seals may either fail or wear. Other leak sources are best determined by facility engineers with experience in similar processes.

**Ventilation** - Normal ventilation or prevailing wind conditions can dictate efficient location of gas sensors in a manner where the migration of gas clouds is quickly detected.

**Personnel Exposure** - The undetected migration of gas clouds should not be allowed to approach concentrated personnel areas such as control rooms, maintenance or warehouse buildings. A more general and applicable thought toward selecting sensor location is combining leak source and perimeter protection in the best possible configuration.

**Note:** In all installations, the sensor points down relative to grade (Fig. 1). Improper sensor orientation may result in false reading and permanent sensor damage.

### 3.5.3 Local Electrical Codes

Sensor and transmitter assemblies should be installed in accordance with all local electrical codes. Use appropriate conduit seals. Drains & breathers are recommended. The sensor assemblies are designed to meet NEC and CSA requirements for Class I; Groups B, C, D; Div. 1 environments.

### 3.5.4 Accessibility

Consideration should be given to easy access by maintenance personnel as well as the consequences of close proximity to contaminants that may foul the sensor prematurely.

Figure #1

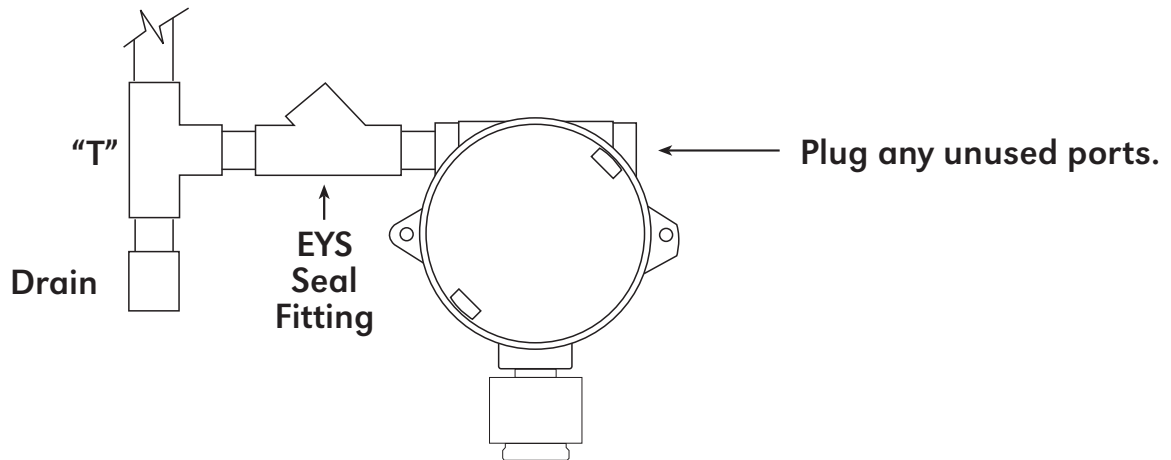

**Note:** An appropriate conduit seal must be located within 18" of the sensor assembly. Crouse Hinds type EYS2, EYD2 or equivalent are suitable for this purpose.

### 3.5.5 Installation Procedure

- Remove the junction box cover and un-plug the control circuit by grasping the two thumb screws and pulling outward.
- Securely mount the sensor junction box in accordance with recommended practice. See dimensional drawing (Fig. 2).
- Observing correct polarity, terminate 3 conductor field wiring, RS-485 wiring, and applicable alarm wiring to the sensor base connector board in accordance with the detail shown in Figure 3. Normally open and normally closed Form C dry contacts (rated 5 amp @ 120VAC; 5 amp @ 30VDC) are provided for Fault, Alarm 1, and Alarm 2.
- Position gold plated jumper tabs located on the connector board in accordance with desired Form C dry contact outputs: NO = Normally Open; NC = Normally closed (see figure 3).

**Note:** If a voltage signal output is desired in place of the 4-20mA output, a 1/4 watt resistor must be installed in position R1 of the terminal board. A 250 $\Omega$  resistor will provide a 1-5V output (- to mA). A 100 $\Omega$  resistor will provide a .4-2V output, etc. This linear signal corresponds to 0-100% of scale (see figure 3).

- Program the alarms via the gold plated jumper tab positions located on the CPU board (see figure 4). Alarm 1 and Alarm 2 have three jumper programmable functions: latching/non-latching relays, normally energized/normally de-energized relays, and ascending/descending alarm set points.

The fault alarm has two jumper programmable functions: latching/non-latching relay, and normally



energized/normally de-energized relay. The default settings of the alarms (jumpers removed) are normally de-energized relays, non-latching relays, and alarm points that activate during descending gas conditions.

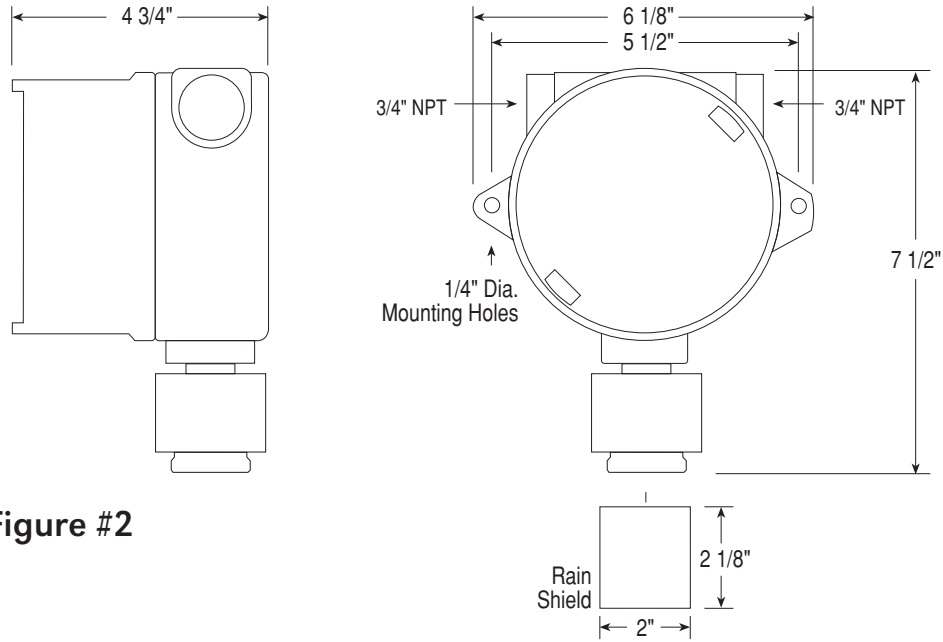

**Figure #2**

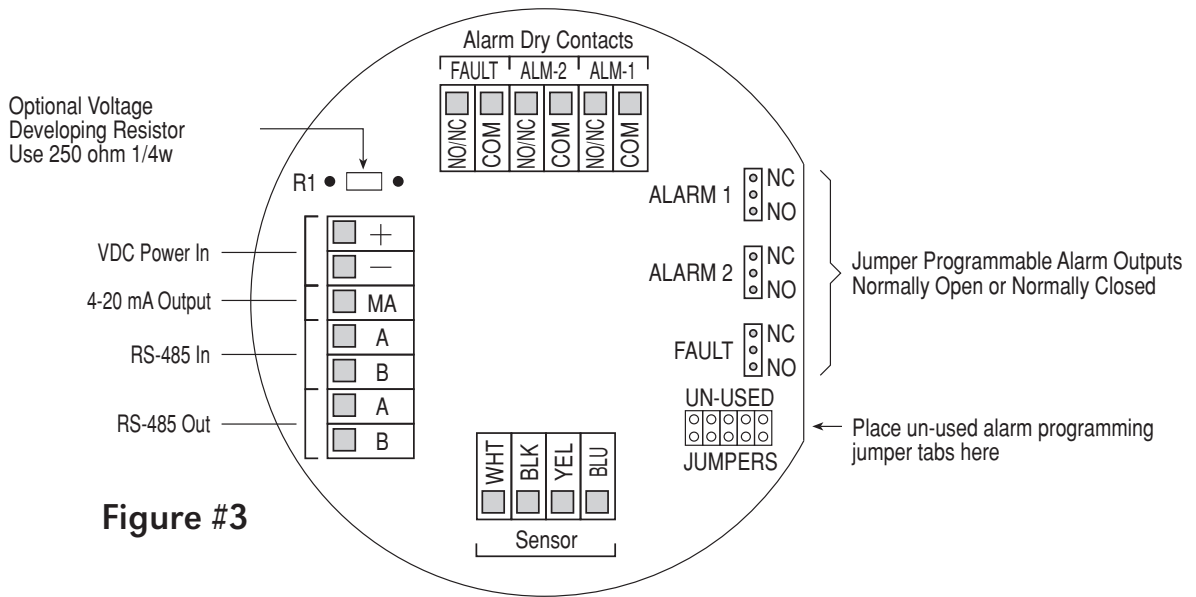
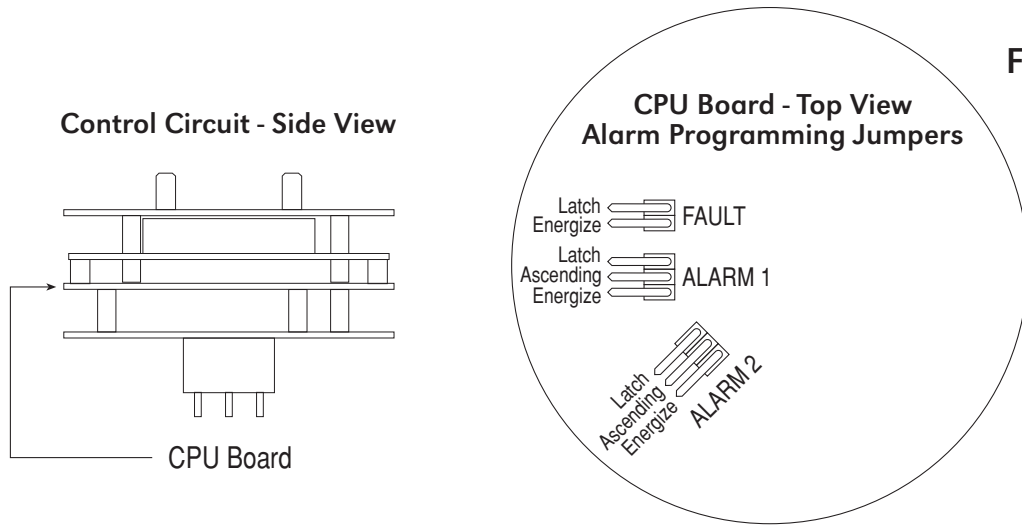

**Figure #3**

If a jumper tab is installed in the latch position, that alarm relay will be in the latching mode. The latching mode will latch the alarm after alarm conditions have cleared until the alarm reset function is activated. The non-latching mode (jumper removed) will allow alarms to de-activate automatically once alarm conditions have cleared. If a jumper tab is installed in the energize position, that alarm relay will be in the energized mode. The energized mode will energize or activate the alarm relay when there is no alarm condition and de-energize or de-activate the alarm relay when there is an alarm condition. The de-energized mode (jumper removed) will energize or activate the alarm relay during an alarm condition and de-energize or de-activate the alarm relay when there is no alarm condition.

If a jumper tab is installed in the ascending position, that alarm relay will be in the ascending mode. The ascending mode will cause an alarm to fire when the gas concentration detected is greater than or equal to the alarm set point. The descending mode (jumper removed) will cause an alarm to fire when the gas concentration detected is lesser than or equal to the alarm set point. Except in special applications, O<sub>2</sub> gas monitoring will require alarms to fire in **“DESCENDING”** gas conditions.

Any unused jumper tabs should be stored on the connector board on the terminal strip labeled “Unused Jumpers” (see figure 3).



**Figure #4**

- f) If applicable, set the RS-485 ID number via the two rotary dip switches located on the pre-amp board (see figure 5). There are 256 different ID numbers available which are based on the hexadecimal numbering system. If RS-485 communications are used, each sensor must have its own unique ID number. Use a jewelers screwdriver to set the rotary dip switches according to the table listed on the following page. If RS-485 communications are not used, leave the dip switches in the default position which is zero/zero (0)-(0).

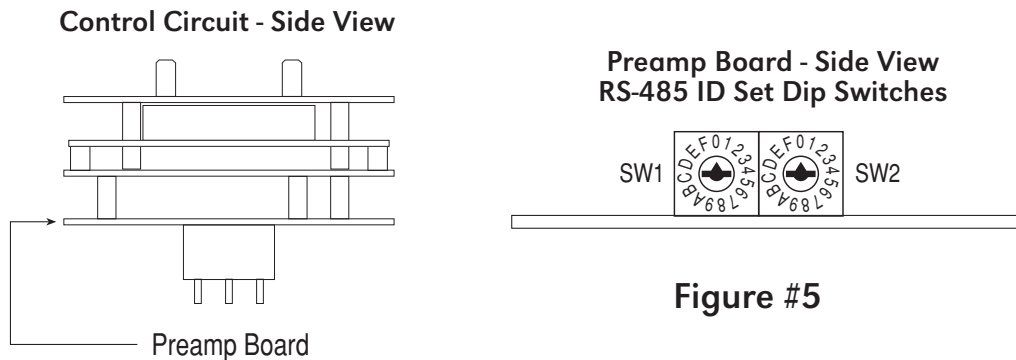

**Figure #5**

ID#	SW1	SW2	ID#	SW1	SW2	ID#	SW1	SW2	ID#	SW1	SW2	ID#	SW1	SW2	ID#	SW1	SW2
none	0	0	43	2	B	86	5	6	129	8	1	172	A	C	215	D	7
1	0	1	44	2	C	87	5	7	130	8	2	173	A	D	216	D	8
2	0	2	45	2	D	88	5	8	131	8	3	174	A	E	217	D	9
3	0	3	46	2	E	89	5	9	132	8	4	175	A	F	218	D	A
4	0	4	47	2	F	90	5	A	133	8	5	176	B	0	219	D	B
5	0	5	48	3	0	91	5	B	134	8	6	177	B	1	220	D	C
6	0	6	49	3	1	92	5	C	135	8	7	178	B	2	221	D	D
7	0	7	50	3	2	93	5	D	136	8	8	179	B	3	222	D	E
8	0	8	51	3	3	94	5	E	137	8	9	180	B	4	223	E	F
9	0	9	52	3	4	95	5	F	138	8	A	181	B	5	224	E	0
10	0	A	53	3	5	96	6	0	139	8	B	182	B	6	225	E	1
11	0	B	54	3	6	97	6	1	140	8	C	183	B	7	226	E	2
12	0	C	55	3	7	98	6	2	141	8	D	184	B	8	227	E	3
13	0	D	56	3	8	99	6	3	142	8	E	185	B	9	228	E	4
14	0	E	57	3	9	100	6	4	143	8	F	186	B	A	229	E	5
15	0	F	58	3	A	101	6	5	144	9	0	187	B	B	230	E	6
16	1	0	59	3	B	102	6	6	145	9	1	188	B	C	231	E	7
17	1	1	60	3	C	103	6	7	146	9	2	189	B	D	232	E	8
18	1	2	61	3	D	104	6	8	147	9	3	190	B	E	233	E	9
19	1	3	62	3	E	105	6	9	148	9	4	191	B	F	234	E	A
20	1	4	63	3	F	106	6	A	149	9	5	192	C	0	235	E	B
21	1	5	64	4	0	107	6	B	150	9	6	193	C	1	236	E	C
22	1	6	65	4	1	108	6	C	151	9	7	194	C	2	237	E	D
23	1	7	66	4	2	109	6	D	152	9	8	195	C	3	238	E	E
24	1	8	67	4	3	110	6	E	153	9	9	196	C	4	239	F	F
25	1	9	68	4	4	111	6	F	154	9	A	197	C	5	240	F	0
26	1	A	69	4	5	112	7	0	155	9	B	198	C	6	241	F	1
27	1	B	70	4	6	113	7	1	156	9	C	199	C	7	242	F	2
28	1	C	71	4	7	114	7	2	157	9	D	200	C	8	243	F	3
29	1	D	72	4	8	115	7	3	158	9	E	201	C	9	244	F	4
30	1	E	73	4	9	116	7	4	159	9	F	202	C	A	245	F	5
31	1	F	74	4	A	117	7	5	160	A	0	203	C	B	246	F	6
32	2	0	75	4	B	118	7	6	161	A	1	204	C	C	247	F	7
33	2	1	76	4	C	119	7	7	162	A	2	205	C	D	248	F	8
34	2	2	77	4	D	120	7	8	163	A	3	206	C	E	249	F	9
35	2	3	78	4	E	121	7	9	164	A	4	207	C	F	250	F	A
36	2	4	79	4	F	122	7	A	165	A	5	208	D	0	251	F	B
37	2	5	80	5	0	123	7	B	166	A	6	209	D	1	252	F	C
38	2	6	81	5	1	124	7	C	167	A	7	210	D	2	253	F	D
39	2	7	82	5	2	125	7	D	168	A	8	211	D	3	254	F	E
40	2	8	83	5	3	126	7	E	169	A	9	212	D	4	255	F	F
41	2	9	84	5	4	127	7	F	170	A	A	213	D	5			
42	2	A	85	5	5	128	8	0	171	A	B	214	D	6			

g) Replace the plug-in control circuit and replace the junction box cover.

### 3.5.6 Remote Mounting Applications

Some sensor mounting applications require that the gas sensor head be remotely mounted away from the sensor transmitter. This is usually true in instances where the gas sensor head must be mounted in a location that is difficult to access. Such a location creates problems for maintenance and calibration activities. Detcon provides the DM-634 sensor in a remote-mount configuration in which the sensor (Model DM-634-RS) and the transmitter (Model DM-634-RT) are provided in their own conduit housing and are interfaced together with a four conductor cable. Reference figure 5A below for wiring diagram.

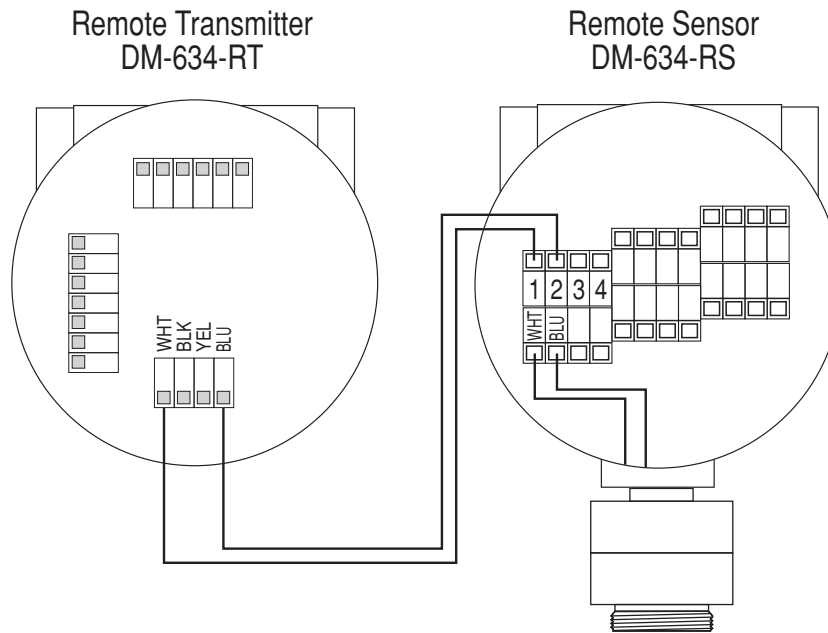

Figure #5A

### 3.6 START UP

Upon completion of all mechanical mounting and termination of all field wiring, apply system power and observe the following normal conditions:

- a) "Fault" LED is off.
- b) A temporary upscale reading may occur as the sensor powers up. This upscale reading will clear to about 20.9% within a few minutes of turn-on, assuming there is no oxygen deficient condition in the area of the sensor.

NOTE: All alarms will be disabled for 1 minute after power up. In the event of power failure, the alarm disable period will begin again once power has been restored.

#### **Initial Operational Tests**

After a warm up period has been allowed for, the sensor should be checked to verify reliable sensitivity to O<sub>2</sub> gas.

#### **Material Requirements**

- \* Detcon P/N 6132 Threaded Calibration Adapter
  - \* Test gas containing 100% nitrogen at a controlled flow rate of 500 ml/min.
- a) Attach the calibration adapter to the threaded sensor housing. Apply the test gas at a controlled flow rate of 500 ml/m. Observe that the LCD display decreases to a level of 3% or less.
  - b) Remove the test gas and observe that the LCD display increases back to 20.9%  $\pm$ 2% of scale (0.5% O<sub>2</sub>).
  - c) If alarms are activated during the test, and have been programmed for latching operation, reset them according to the instructions in section 3.9.2.

Initial operational tests are complete. Detcon O<sub>2</sub> gas sensors are pre-calibrated prior to shipment and will, in most cases, not require significant adjustment on start up. However, it is recommended that a complete calibration test and adjustment be performed within 24 hours of installation. Refer to calibration instructions in later text.

### 3.7 CALIBRATION

#### **Material Requirements**

- \* Detcon P/N 3270 MicroSafe™ Programming Magnet
- \* Detcon P/N 6132 Threaded Calibration Adapter
- \* Test gas containing 100% nitrogen at a controlled flow rate of 500 ml/min.

### ***Programming Magnet Operating Instructions***

Operator interface to MicroSafe™ gas detection products is via magnetic switches located behind the transmitter face plate. DO NOT remove the glass lens cover to calibrate or change programming parameters. Two switches labeled “PGM 1” and “PGM 2” allow for complete calibration and alarm level programming without removing the enclosure cover, thereby eliminating the need for area de-classification or the use of hot permits.

A magnetic programming tool (see figure 6) is used to operate the switches. Switch action is defined as momentary contact, 3 second hold, and 30 second hold. In momentary contact use, the programming magnet is waved over a switch location. In 3 second hold, the programming magnet is held in place over a switch location for 3 or more seconds. In 30 second hold, the programming magnet is held in place over a switch location for 30 or more seconds. Three and thirty second hold is used to enter or exit calibration and program menus while momentary contact is used to make adjustments. The location of “PGM 1” and “PGM 2” are shown in figure 7.

NOTE: If, after entering the calibration or program menus, there is no interaction with the menu items for more than 30 seconds, the sensor will return to its normal operating condition.

**Figure #6**

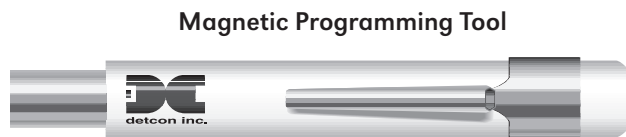

### **3.7.2 Calibration Procedure - Span**

NOTE : Before performing an ambient air O<sub>2</sub> span calibration, be sure there is no oxygen-deficient condition present.

**CAUTION:** Verification of the correct calibration gas level setting and calibration span gas concentration is required before “span” calibration. These two numbers must be equal.

Calibration consists of entering the calibration function and following the menu-displayed instructions. The display will ask for the application of span gas in a specific concentration. This concentration must be equal to the calibration gas level setting. The factory default setting for span gas concentration is 20.9% O<sub>2</sub> which is the normal atmospheric concentration. Other concentrations may be used as long as they fall within 15.0% to 25.0% O<sub>2</sub>. However, any alternate span gas concentration value must be programmed via the calibration gas level menu before proceeding with span calibration. Follow the instructions below for span calibration.

- a) Verify the current calibration gas level setting as indicated by the programming status menu. To do this, follow the instructions in section 3.8 and make note of the setting found in listing number 12. The item appears as “**CalGas @ xx.x %**”.
- b) If the calibration gas level setting is equal to your calibration span gas concentration, proceed to item “f”. If not, adjust the calibration gas level setting so that it is equal to your calibration span gas concentration, as instructed in items “c” through “e”.
- c) Enter the programming menu by holding the programming magnet stationary over “PGM 2” for 30 seconds until the display reads “**VIEW PROG STATUS**”, then withdraw the magnet. At this point you can scroll through the programming menu by momentarily waving the programming magnet over “PGM 1” or “PGM 2”. The menu options are: View Program Status, Set Alarm 1 Level, Set Alarm 2 Level, and Set Cal Level.

Figure #7

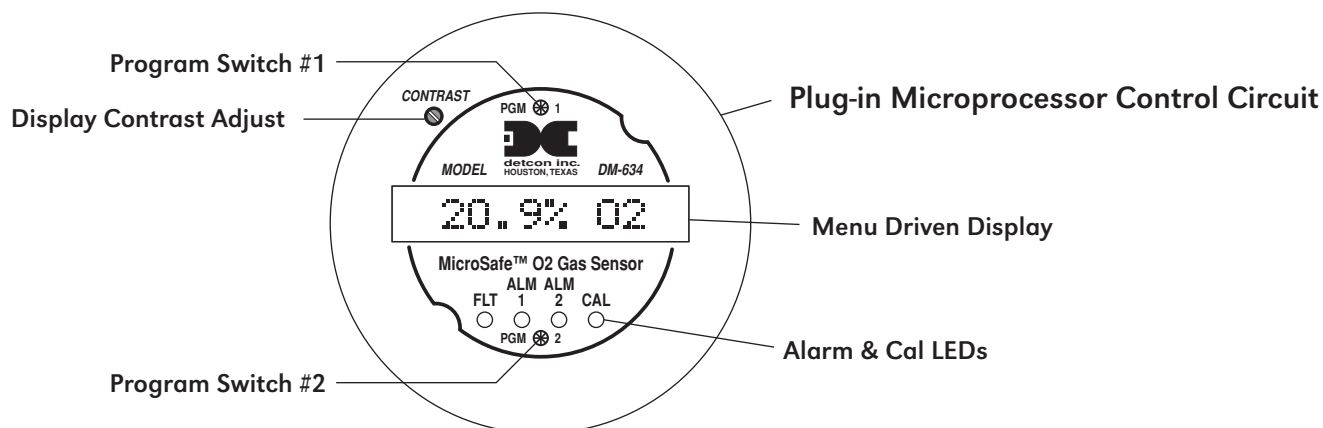

- d) From the programming menu scroll to the calibration level listing. The menu item appears as: **“SET CAL LEVEL”**. Enter the menu by holding the programming magnet stationary over “PGM 1” for 3 seconds until the display reads **“CalGas @ ## %”**, then withdraw the magnet. Use the programming magnet to make an adjustment to “PGM 1” to increase or “PGM 2” to decrease the display reading until the reading is equal to the desired calibration span gas concentration. Exit to the programming menu by holding the programming magnet over “PGM1” for 3 seconds.
- e) Exit back to normal operation by holding the programming magnet over “PGM 2” for 3 seconds, or automatically return to normal operation in 30 seconds.
- f) From the calibration menu **“2-SPAN”** (section 3.7.1-a) proceed into the span adjust function by holding the programming magnet stationary over “PGM 2” for 3 seconds then withdraw the programming magnet. If no change of Span level is desired, wait 30 seconds for menu to return to normal operation. At this point the display will ask for the application of the target gas and concentration. The display reads **“APPLY xx.x %”** The xx.x here will indicate the actual concentration requested.
- g) Apply the calibration test gas at a flow rate of 500 milliliters per minute. If the calibration gas level is set at 20.9% and ambient air is verified to be 20.9% (normal atmospheric concentration of O2) then do nothing at this point. The sensor will auto calibrate to ambient air O2 concentration. After 3 minutes the sensor will auto span to the correct reading and the display will change to **“REMOVE GAS”** then the display will return to the normal operating mode.

NOTE 1: If the circuitry is unable to adjust the span to the proper setting the sensor will enter into the calibration fault mode which will cause the display to alternate between the sensor’s current status reading and the calibration fault screen which appears as: **“CAL FAULT”** (see section 3.7.3).

### 3.7.3 Additional Notes

1. Upon entering the calibration menu, the 4-20 mA signal drops to 2 mA and is held at this level until you return to normal operation.
2. If during calibration the sensor circuitry is unable to attain the proper adjustment for span, the sensor will enter into the calibration fault mode which will activate fault alarm functions (see section 3.10) and cause the display to alternate between the sensor’s current status reading and the calibration fault screen which appears as: **“CAL FAULT”**. If this occurs you may attempt to recalibrate by entering the calibration menu as described in section 3.7.1-a. If the sensor fails again, defer to technical trouble shooting.

### 3.7.4 Calibration Frequency

In most applications, monthly to quarterly calibration intervals will assure reliable detection. However, industrial environments differ. Upon initial installation and commissioning, close frequency tests should be performed, weekly to monthly. Test results should be recorded and reviewed to determine a suitable calibration interval.

## 3.8 STATUS OF PROGRAMMING, ALARMS, CALIBRATION LEVEL, RS-485 ID, AND SENSOR LIFE

The programming menu has a programming status listing that allows the operator to view the gas, range, and software version number of the program, as well as the current alarm settings, calibration gas level setting, RS-485 ID number, and estimated remaining sensor life. The programming menu also allows the changing of alarm levels (see section 3.9) and the programming of the calibration gas level setting (see section 3.7.2).

The following procedure is used to view the programming status of the sensor:

- a) First, enter the programming menu by holding the programming magnet stationary over “PGM 2” for 30 seconds until the display reads “**VIEW PROG STATUS**”, then withdraw the magnet. At this point you can scroll through the programming menu by momentarily waving the programming magnet over “PGM 1” or “PGM 2”. The menu options are: View Program Status, Set Alarm 1 Level, Set Alarm 2 Level, and Set Cal Level.
- b) Next, scroll to the “**VIEW PROG STATUS**” listing and then hold the programming magnet over “PGM 1” for 3 seconds. The menu will then automatically scroll, at five second intervals, through the following information before returning back to the “**VIEW PROG STATUS**” listing.

- 1 - The gas type, range of detection and software version number. The menu item appears as: “**O2 0-25 V528J**”
- 2 - The alarm set point level of alarm 1. The menu item appears as: “**ALM1 SET @ 19.5%**”
- 3 - The alarm firing direction of alarm 1. The menu item appears as: “**ALM1 DESCENDING**”
- 4 - The alarm relay latch mode of alarm 1. The menu item appears as: “**ALM1 NONLATCHING**”
- 5 - The alarm relay energize state of alarm 1. The menu item appears as: “**ALM1 DE-ENERGIZED**”
- 6 - The alarm set point level of alarm 2. The menu item appears as: “**ALM2 SET @ 17.5%**”
- 7 - The alarm firing direction of alarm 2. The menu item appears as: “**ALM2 DESCENDING**”
- 8 - The alarm relay latch mode of alarm 2. The menu item appears as: “**ALM2 LATCHING**”
- 9 - The alarm relay energize state of alarm 2. The menu item appears as: “**ALM2 DE-ENERGIZED**”
- 10 - The alarm relay latch mode of the fault alarm. The menu item appears as: “**FLT NONLATCHING**”
- 11 - The alarm relay energize state of the fault alarm. The menu item appears as: “**FLT ENERGIZED**”
- 12 - Calibration gas level setting. The menu appears as “**CalLevel @ xx.x%**”
- 13 - Identification of the RS-485 ID number setting. The menu item appears as: “**485 ID SET @ 1**”
- 14 - The estimated remaining sensor life. The menu item appears as: “**SENSOR LIFE 100%**”

- c) Exit back to normal operations by holding the programming magnet over “PGM 2” for 3 seconds, or automatically return to normal operation in 30 seconds.

## 3.9 PROGRAMMING ALARMS

### 3.9.1 Alarm Levels

Both alarm 1 and alarm 2 levels are factory set prior to shipment. Alarm 1 is set at 19.5%; alarm 2 at 17.5%. Both alarms can be set in 0.1% increments from 2.5% to 22.5%. The following procedure is used to change alarm set points:

- a) First, enter the programming menu by holding the programming magnet stationary over “PGM 2” for 30 seconds until the display reads “**VIEW PROG STATUS**”, then withdraw the magnet. At this point you can scroll through the programming menu by momentarily waving the programming magnet over “PGM 1” or “PGM 2”. The menu options are: View Program Status, Set Alarm 1 Level, Set Alarm 2 Level, and Set Cal Level.
- b) ALARM 1 LEVEL From the programming menu scroll to the alarm 1 level listing. The menu item appears as:

**“SET ALARM 1 LEVEL”**. Enter the menu by holding the programming magnet stationary over “PGM 1” for 3 seconds until the display reads **“SET ALM1 @ 19.5%”**, then withdraw the magnet. Use the programming magnet to make an adjustment to “PGM 1” to increase or “PGM 2” to decrease the display reading until the reading is equal to the desired alarm set point. Exit to the programming menu by holding the programming magnet over “PGM1” for 3 seconds, or automatically return to the programming menu in 30 seconds.

- c) ALARM 2 LEVEL From the programming menu scroll to the alarm 2 level listing. The menu item appears as: **“SET ALARM 2 LEVEL”**. Enter the menu by holding the programming magnet stationary over “PGM 1” for 3 seconds until the display reads **“SET ALM2 @ 17.5%”**, then withdraw the magnet. Use the programming magnet to make an adjustment to “PGM 1” to increase or “PGM 2” to decrease the display reading until the reading is equal to the desired alarm set point. Exit to the programming menu by holding the programming magnet over “PGM1” for 3 seconds, or automatically return to the programming menu in 30 seconds.
- d) Exit back to normal operations by holding the programming magnet over “PGM 2” for 3 seconds, or automatically return to normal operation in 30 seconds.

### 3.9.2 Alarm Reset

An alarm condition will cause the applicable alarm to activate its corresponding relay and LED. If alarm 1, alarm 2, or fault alarms have been programmed for latching relays, an alarm reset function must be activated to reset the alarms after an alarm condition has cleared. To reset the alarms, simply wave the programming magnet over either “PGM 1” or “PGM 2”, momentarily, while in normal operations mode and note that the corresponding alarm LED(s) turn off.

### 3.9.3 Other Alarm Functions

Alarms are factory programmed to be non-latching, de-energized; and to fire under ascending gas conditions. The fault alarm relay is programmed as normally energized which is useful for detecting a 24VDC power source failure. All alarm functions are programmable via jumper tabs. Changing alarm functions requires the sensor housing to be opened, thus declassification of the area is required. See section 3.5.4-e for details.

## 3.10 PROGRAM FEATURES

Detcon MicroSafe™ toxic gas sensors incorporate a comprehensive program to accommodate easy operator interface and fail-safe operation. Program features are detailed in this section. Each sensor is factory tested, programmed, and calibrated prior to shipment.

### ***Over Range***

When the sensor detects gas greater than 25.0% O<sub>2</sub>, it will cause the display to flash **“25.0 % O<sub>2</sub>”** on and off.

### ***Sensor Fault***

If either of the wires connecting the sensor cell to the connector board should fail and cause an open circuit, the sensor will go into a fault condition. **“SENSOR FAULT”**.

### ***Calibration Fault***

If during calibration the sensor circuitry is unable to attain the proper adjustment for span, the sensor will enter into the calibration fault mode and cause the display to alternate between the sensor’s current status reading and the calibration fault screen which appears as: **“CAL FAULT”**.

### ***Fail-Safe/Fault Supervision***

Detcon MicroSafe™ sensors are programmed for fail-safe operation. Any fault condition will activate the fault relay, illuminate the fault LED, and cause the display to read its corresponding fault condition: **“SENSOR FAULT”**, or **“CAL FAULT”**. A “SENSOR FAULT” will also cause the mA output to drop to zero (0) mA.

### ***Sensor Life***

The sensor life feature is a reference based on signal output from the sensor cell. When a sensor life of 25% or less remains, the sensor cell should be replaced within a reasonable maintenance schedule.

## 3.11 RS-485 PROTOCOL

Model TP-624C MicroSafe™ sensors feature Modbus™ compatible communications protocol and are addressable via rotary dip switches for multi-point communications. Other protocols are available. Contact the Detcon factory for specific protocol requirements. Communication is two wire, half duplex 485, 9600 baud, 8 data bits, 1 stop bit,



no parity, with the sensor set up as a slave device. A master controller up to 4000 feet away can theoretically poll up to 256 different sensors. This number may not be realistic in harsh environments where noise and/or wiring conditions would make it impractical to place so many devices on the same pair of wires. If a multi-point system is being utilized, each sensor should be set for a different address. Typical address settings are: 01, 02, 03, 04, 05, 06, 07, 08, 09, 0A, 0B, 0C, 0D, 0E, 0F, 10, 11, etc.

In most instances, RS-485 ID numbers are factory set or set during installation before commissioning. If required, the RS-485 ID number can be set via rotary dip switches located on the pre-amp circuit board. However, any change to the RS-485 ID number would require the sensor housing to be opened, thus declassification of the area would be required. See section 3.5.5-f for details on changing the RS-485 ID number.

The following section explains the details of the Modbus™ protocol that the DM-634 MicroSafe™ sensor supports.

Code 03 - Read Holding Registers, is the only code supported by the transmitter. Each transmitter contains 6 holding registers which reflect its current status.

<u>Register #</u>	<u>High Byte</u>	<u>Low Byte</u>
40000	Gas type	Sensor Life

Gas type is one of the following:

01=CO, 02=H2S, 03=SO2, 04=H2, 05=HCN, 06=CL2, 07=NO2, 08=NO, 09=HCL, 10=NH3, 11=LEL, 12=O2

Sensor life is an estimated remaining use of the sensor head, between 0% and 100%

Example: 85=85% sensor life

<u>Register #</u>	<u>High Byte</u>	<u>Low Byte</u>
40001		Detectable Range

i.e. 100 for 0-100 ppm, 50 for 0-50% LEL, etc.

<u>Register #</u>	<u>High Byte</u>	<u>Low Byte</u>
40002		Current Gas Reading

The current gas reading as a whole number. If the reading is displayed as 23.5 on the display, this register would contain the number 235.

<u>Register #</u>	<u>High Byte</u>	<u>Low Byte</u>
40003		Alarm 1 Setpoint

This is the trip point for the first alarm.

<u>Register #</u>	<u>High Byte</u>	<u>Low Byte</u>
40004		Alarm 2 Setpoint

This is the trip point for the second alarm.

<u>Register #</u>	<u>High Byte</u>	<u>Low Byte</u>
40005	Status Bits	Status Bits

High Byte

Bit 7	Not used, always 0
Bit 6	Not used, always 0
Bit 5	Not used, always 0
Bit 4	Not used, always 0

Bit 3	1-Unit is in calibration	0-Normal operation
Bit 2	1-Alarm 2 is ascending	0-Alarm 2 is descending
Bit 1	1-Alarm 2 is normally energized	0-Alarm 2 is normally de-energized
Bit 0	1-Alarm 2 is latching	0-Alarm 2 is non-latching

Low Byte

Bit 7	1-Alarm 2 Relay is energized	0-Alarm 2 Relay is not energized
Bit 6	1-Alarm 1 is ascending	0-Alarm 1 is descending
Bit 5	1-Alarm 1 is normally energized	0-Alarm 1 is normally de-energized
Bit 4	1-Alarm 1 is latching	0-Alarm 1 is non-latching
Bit 3	1-Alarm 1 Relay is energized	0-Alarm 1 Relay is not energized
Bit 2	1-Fault is normally energized	0-Fault is normally de-energized
Bit 1	1-Fault is latching	0-Fault is non-latching
Bit 0	1-Fault Relay is energized	0-Fault Relay is not energized

The following is a typical Master Query for device # 8:

<u>Field Name</u>	<u>HEX</u>	<u>DEC</u>	<u>RTU</u>
Slave Address	08	8	0000 1000
Function	03	3	0000 0011
Start Address Hi	00	0	0000 0000
Start Address Lo	00	0	0000 0000
No. of Registers Hi	00	0	0000 0000
No. of Registers Lo	06	6	0000 0110
CRC	##		#####
CRC	##		#####

The following is a typical Slave Response from device # 8:

<u>Field Name</u>	<u>HEX</u>	<u>DEC</u>	<u>RTU</u>
Slave Address	08	8	0000 1000
Function	03	3	0000 0011
Byte Count	0C	12	0000 1100
Reg40000 Data Hi	02	2	0000 0010
Reg40000 Data Lo	64	100	0110 0100
Reg40001 Data Hi	00	0	0000 0000
Reg40001 Data Lo	64	100	0110 0100
Reg40002 Data Hi	00	0	0000 0000
Reg40002 Data Lo	07	7	0000 0111
Reg40003 Data Hi	00	0	0000 0000
Reg40003 Data Lo	0A	10	0000 1010
Reg40004 Data Hi	00	0	0000 0000
Reg40004 Data Lo	14	20	0001 0100
Reg40005 Data Hi	05	5	0000 0101
Reg40005 Data Lo	50	80	0101 0000
CRC	##		#####
CRC	##		#####

Additional Notes:

The calibration LED will light when the transmitter is sending a response to a Master Query. Communications are 9600 baud, 8 data bits, 1 stop bit, No parity, half duplex 485.

## 3.12 DISPLAY CONTRAST ADJUST

Detcon MicroSafe™ sensors feature a 16 character backlit liquid crystal display. Like most LCD, character contrast can be affected by viewing angle and temperature. Temperature compensation circuitry included in the MicroSafe™ design will compensate for this characteristic, however temperature extremes may still cause a shift in the contrast. Display contrast can be adjusted by the user if necessary. However, changing the contrast requires that the sensor housing be opened, thus declassification of the area is required.

To adjust the display contrast, remove the enclosure cover and use a jewelers screwdriver to turn the contrast adjust screw located beneath the metallic face plate. The adjustment location is marked “CONTRAST”. See figure 7 for location.

## 3.12A TROUBLE SHOOTING

### Memory or Error Reports

1. Re-initialize Sensor - Unplug transmitter and re-plug transmitter then swipe magnet over PGM 1 in the first 3 seconds. This will clear the processor and recover from error state. Remember to put in all customer settings for range, alarm and cal gas level after re-initialization.

### Non-readable Display

1. If display has blue background when hot, install sunshade to reduce temperature.
2. If poor contrast, adjust contrast pot accordingly.

### Nothing Displayed - Transmitter not Responding

1. Verify condulet has no accumulated water or abnormal corrosion.
2. Verify required DC power is applied to correct terminals.
3. Swap with a known-good transmitter to determine if transmitter is faulty.

### Bad 4-20 mA Output or RS485 Output

1. Check that wiring is connected to correct terminal outputs.
2. Swap with a known-good transmitter to determine if transmitter is faulty.

## 3.13 SPARE PARTS LIST

613-120000-700	Sensor splash guard
943-000006-132	Threaded Calibration Adapter for DM
500-001794-004	Connector board
327-000000-000	Programming Magnet
897-850800-000	3 port enclosure less cover
897-850700-000	Enclosure glass lens cover
960-202200-000	Condensation prevention packet (replace annually).
370-399100-000	Plug in replacement O2 sensor cell
926-345500-025	Plug in control circuit
399-200000-000	Stainless steel sensor housing assembly (does not include plug in sensor)

## 3.14 WARRANTY

Detcon, Inc., as manufacturer, warrants each new plug-in O2 sensor cell (P/N 370-399100-000), for a two year period under the conditions described as follows: The warranty period begins on the date of shipment to the original purchaser and ends two years thereafter. The sensor cell is warranted to be free from defects in material and workmanship. Should the sensor cell fail to perform in accordance with published specifications within the warranty period, return the defective part to Detcon, Inc., 3200 A-1 Research Forest Dr., The Woodlands, Texas 77381, for necessary repairs or replacement.

### 3.15 SERVICE POLICY

Detcon, Inc., as manufacturer, warrants under intended normal use each new MicroSafe™ plug-in control circuit to be free from defects in material and workmanship for a period of two years from the date of shipment to the original purchaser. Detcon, Inc., further provides for a five year fixed fee service policy wherein any failed transmitter shall be repaired or replaced as is deemed necessary by Detcon, Inc., for a fixed fee of \$65.00. The fixed fee service policy shall affect any factory repair for the period following the two year warranty and shall end five years after expiration of the warranty. All warranties and service policies are FOB the Detcon facility located in The Woodlands, Texas.

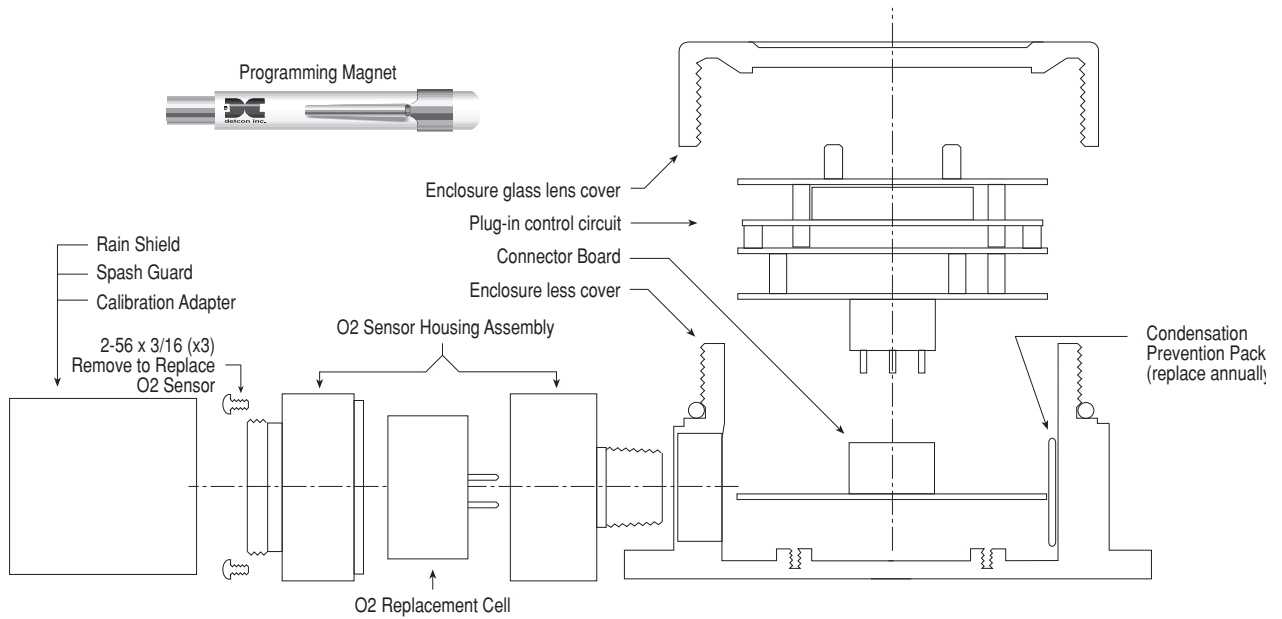

### 3.16 SOFTWARE FLOW CHART

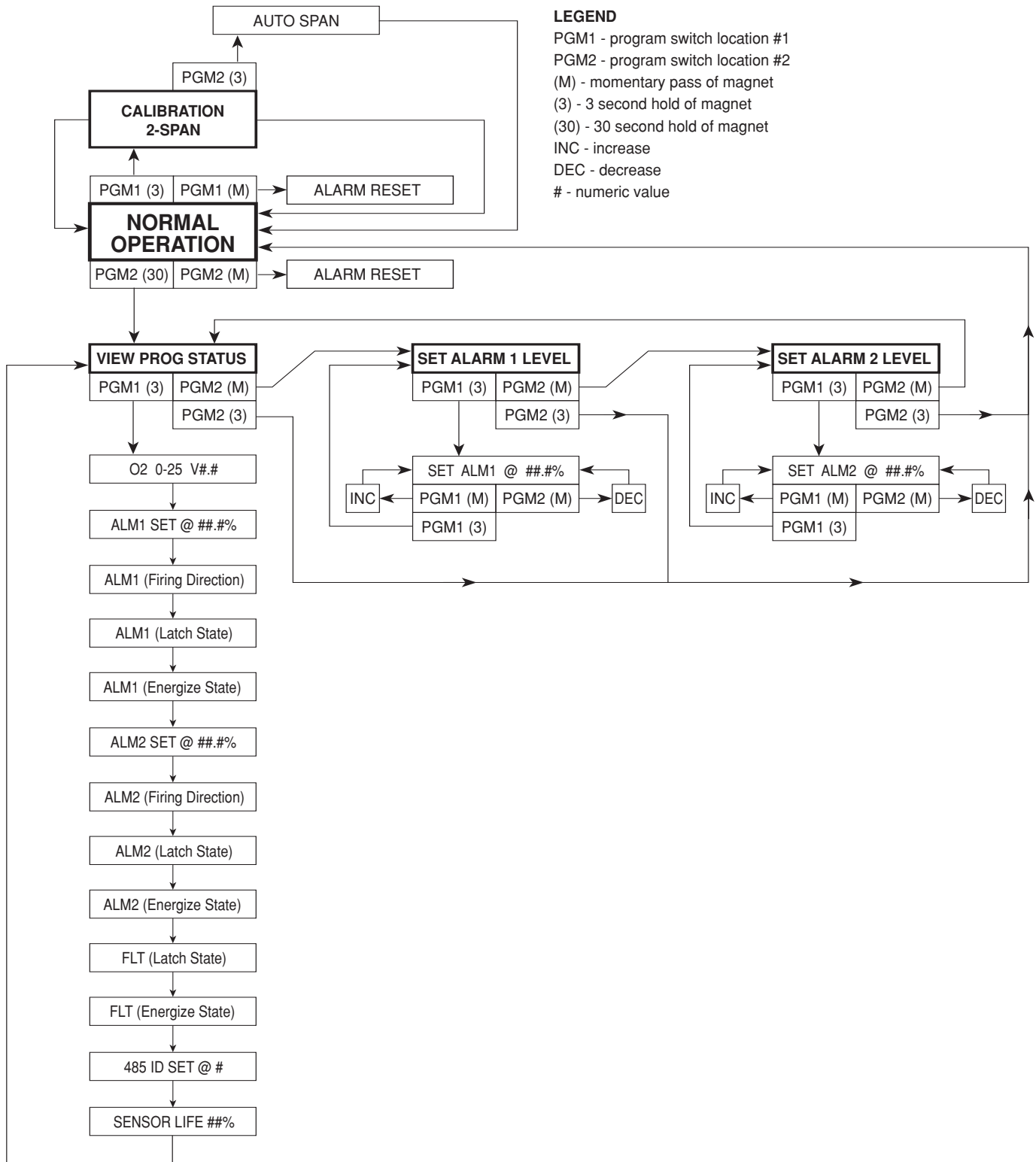

Shipping Address: 3200 A-1 Research Forest Dr., The Woodlands, Texas 7381  
 Mailing Address: P.O. Box 8067, The Woodlands, Texas 77387-8067  
 phone 888-367-4286, 713-559-9200 • fax 281-292-2860 • www.detcon.com • sales@detcon.com