



Detcon MicroSafe™

IR-622 Combustible Hydrocarbon Sensor (0-100% LEL)



Operator's Installation & Instruction Manual

November 26, 2007 • Document #2195 • Version 6.3

CAUTION:

Before operating the Model IR-622 sensor, read this manual thoroughly and verify that the configuration of default factory settings are appropriate and correct for your application. The settings include: relay contact outputs (section 3.5.5d), alarm settings (section 3.5.5e and 3.9), and RS485 ID (section 3.5.5f and 3.12).

Table of Contents

- 3.0 Description
- 3.1 Principle of Operation
- 3.2 Application
- 3.3 Specifications
- 3.4 Operating Software
- 3.5 Installation
- 3.6 Start-up
- 3.7 Calibration
- 3.8 Status of Programming, Alarms, Calibration Level, RS-485 ID, and Sensor Life
- 3.9 Programming Alarms
- 3.10 Program Features
- 3.11 RS-485 Protocol
- 3.12 Display Contrast Adjust
- 3.13 Optical Sensor Replacement
- 3.14 Troubleshooting
- 3.15 Spare Parts List
- 3.16 Warranty
- 3.17 Service Policy
- 3.18 Software Flow Chart

3.0 DESCRIPTION

Detcon MicroSafe™ Model IR-622, combustible hydrocarbon gas sensors are non-intrusive “Smart” sensors designed to detect and monitor combustible hydrocarbon gas in air over the range of 0-100% lower explosive limit (LEL). One of the primary features of the sensor is its method of automatic calibration which guides the user through each step via instructions displayed on the backlit LCD. The sensor features field adjustable, fully programmable alarms and provides relays for two alarms plus fault as standard. The sensor comes with two different outputs: analog 4-20 mA, and serial RS-485. These outputs allow for greater flexibility in system integration and installation. The microprocessor supervised electronics are packaged as a plug-in module that mates to a standard connector board. Both are housed in an explosion proof conduit that includes a glass lens window which allows for the display of sensor readings as well as access to the sensor’s menu driven features via a hand-held programming magnet.

The sensor technology is a field proven “plug-in replaceable” non-dispersive infrared (NDIR) optical type. NDIR optical sensors show an excellent response to a long list of combustible hydrocarbon gases. This technique is non-selective and may be used for the detection and monitoring of many target combustible hydrocarbon gases. As compared to catalytic bead sensors, with NDIR there is no risk of sensor poisoning, no risk of high concentration saturation, and no need for O₂ to be present. The NDIR type sensor is characteristically stable for both span and zero and is capable of providing reliable performance with low maintenance requirements for periods approaching 5 years in most industrial environments.



3.0.1 Non-dispersive Infrared (NDIR) Optical Sensor

The Detcon NDIR sensor is designed as a miniature single piece “plug-in replaceable” component, which can easily be changed out in the field. The NDIR sensor consists of an infrared lamp source, two pyroelectric detectors, and an optical gas sample cavity. The lamp source produces infrared radiation which interacts with the target gas as it travels through the optical gas sample cavity. The infrared radiation contacts each of two pyroelectric detectors at the completion of the optical path. The “active” pyroelectric detector is covered by a filter specific to the part of the IR spectrum where the target gas absorbs light. The “reference” pyroelectric detector is covered by a filter specific to the non-absorbing part of the IR spectrum. When the target gas is present, it absorbs IR radiation and the signal output from the “active” pyroelectric detector decreases accordingly while the “reference” detector output remains unchanged. The ratio of the “active” and “reference” detector outputs is then used to compute the target gas concentration.

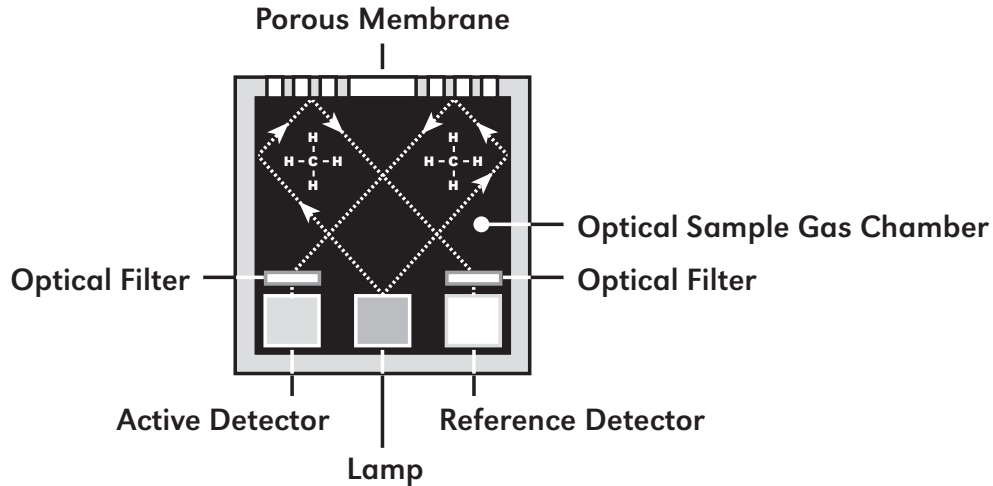

3.0.2 Microprocessor Control Circuit

The control circuit is microprocessor based and is packaged as a plug-in field replaceable module, facilitating easy replacement and minimum down time. Circuit functions include a basic sensor pre-amplifier, sensor temperature measurement, on-board power supplies, microprocessor, back lit alpha numeric display, alarm status LED indicators, magnetic programming switches, an RS-485 communication port, and a linear 4-20 mA DC output.

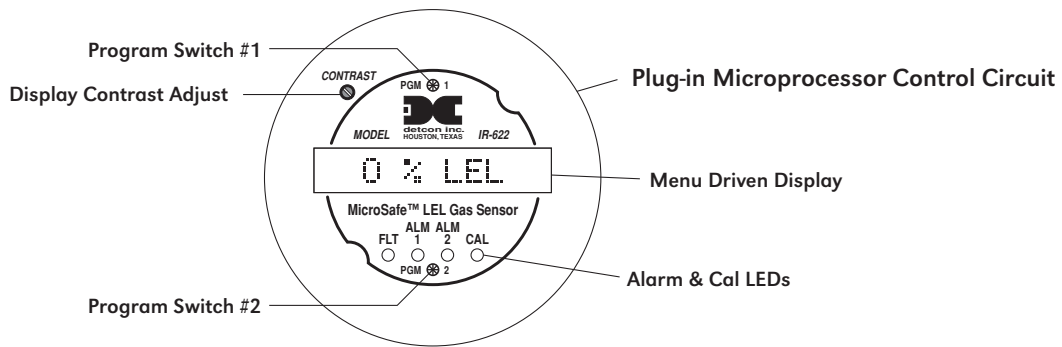

3.0.3 Base Connector Board

The base connector board is mounted in the explosion proof enclosure and includes: the mating connector for the control circuit, reverse input and secondary transient suppression, input filter, alarm relays, lugless terminals for all field wiring, and a terminal strip for storing unused programming jumper tabs. The alarm relays are contact rated 5 amps @ 250 VAC, 5 amps @ 30 VDC and coil rated at 24 VDC. Gold plated program jumpers are used to select either the normally open or normally closed relay contacts.

3.0.4 Explosion Proof Enclosure

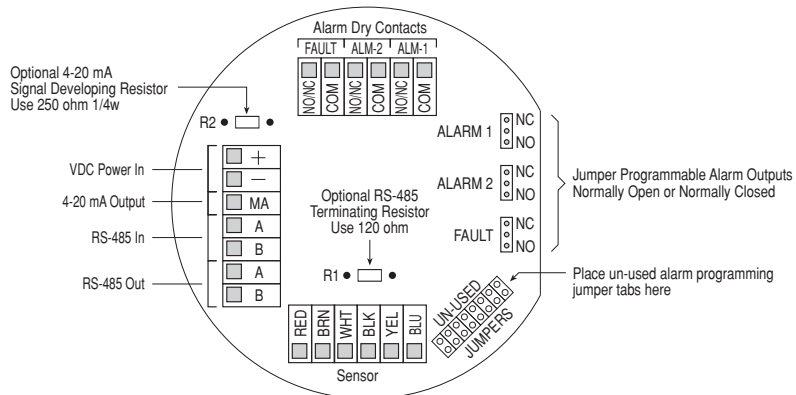

The sensors are packaged in a cast metal explosion proof enclosure. The enclosure is fitted with a threaded cover that has a glass lens window. Magnetic program switches located behind the transmitter module face plate are activated through the lens window via a hand-held magnetic programming tool allowing non-intrusive operator interface with the sensor. All calibration and alarm level adjustments can be accomplished without removing the cover or declassifying the area. Electrical classification is Class I; Groups B, C, D; Div. 1.

3.1 PRINCIPLE OF OPERATION

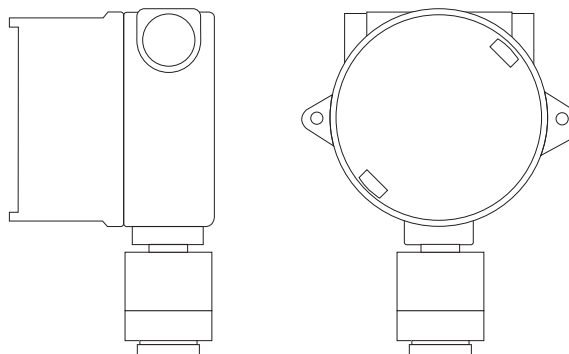

The target gas diffuses through a sintered stainless steel flame arrestor and into the volume of the sample gas optical cavity. A lamp source provides a cyclical IR radiation source which travels through the optical gas sample cavity and terminates at two pyroelectric detectors. The “active” and “reference” pyroelectric detectors each give an output which measures the intensity of the radiation contacting their surface. The “active” pyroelectric detector is covered by an optical filter specific to the part of the IR spectrum where the target gas absorbs light. The “reference” pyroelectric detector is covered by a filter specific to the non-absorbing part of the IR spectrum. When present, the target gas absorbs a fraction of the IR radiation and the signal output from the “active” pyroelectric detector decreases accordingly. The signal output of the “reference” detector remains unchanged in the presence of the target gas. The ratio of the “active” and “reference” detector signal outputs is then used to compute the target gas concentration. By using the ratio of the active/reference signal outputs, measurement drift caused by changes in the intensity of the lamp source and changes in the optical path are negated.

3.1.2 Characteristics

The NDIR optical sensor element maintains strong sensitivity to combustible hydrocarbon gases in air in the lower explo-

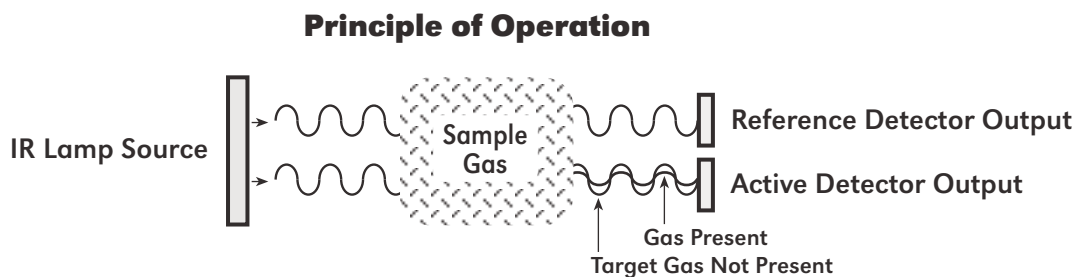

sive range (0-100% LEL), as shown in the illustration below. When compared with the typical catalytic bead LEL sensor, the NDIR sensor exhibits excellent long-term zero and span stability. Typical zero calibration intervals would be monthly to quarterly and typical span calibration intervals would be semi-annual to annual. However, actual field experience is always the best determination of appropriate calibration intervals.

NOTE: The IR-622 detector will not respond to combustible gases such as H₂, NH₃, CO, etc, which are not hydrocarbons.

The MicroSafe™ IR-622 is factory calibrated for a specific target gas. Unless otherwise specified, the detector will be factory calibrated for methane service. If a combustible hydrocarbon gas other than methane is being measured, contact Detcon for the appropriate field-replaceable electronics/software upgrade.

The NDIR optical sensor readings can be adversely affected by dust, dirt and oil mist accumulation as well as severe corrosion. These deposits may reduce the optical reflectivity inside the sensor, and although accurate readings are continually main-

tained, excessive loss in useable signal eventually gives way to noise and unstable readings. The optical sensor may, over long periods of time (3-7 years), lose its IR lamp source filament, and in this case an optical sensor modular replacement is required. The IR-622 has an extensive list of Fault Diagnostics to alert and pin-point operational problems. See section 3.10

3.2 APPLICATION

Output Response Curve

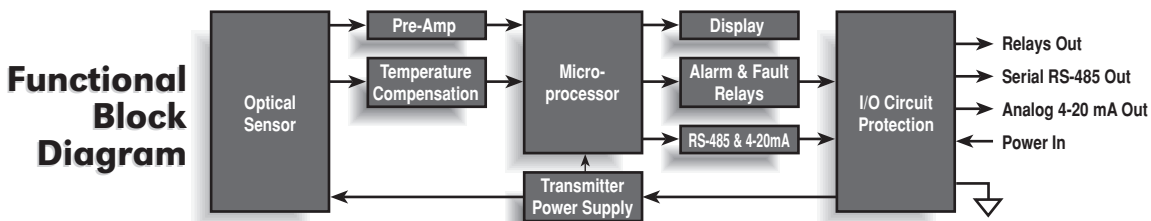
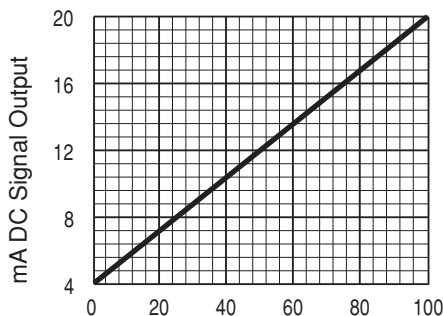

Model IR-622 MicroSafe™ sensors are designed to detect and monitor combustible hydrocarbon gas in ambient air in the range of 0-100% LEL. Minimum sensitivity and scale resolution is 1%. Operating temperature range is -40° F. to +175° F. While the sensor is capable of operating outside these temperatures, performance specifications are verified within the limit.

3.2.1 Sensor Placement/Mounting

Sensor location should be reviewed by facility engineering and safety personnel. Area leak sources and perimeter mounting are typically used to determine number and location of sensors. The sensors are generally located 2 - 4 feet above grade.

3.2.2 Response to Different Gases

The MicroSafe™ IR-622 responds to all combustible hydrocarbon gases, but at different signal strengths. In order to maintain accurate readings, the detector must be calibrated to the specific target gas of interest.

The MicroSafe™ IR-622 is factory calibrated for the specific target gas chosen at the time of order. Unless otherwise specified by the customer, the detector will be factory calibrated for methane service. Once installed in the field, if a combustible hydrocarbon gas other than the gas specified at the time of order is being measured, contact Detcon for the appropriate field-replaceable electronics/software upgrade. The calibration gas used to span the IR-622 must be the same gas type as the target gas being measured.

3.3 SPECIFICATIONS

Method of Detection

NDIR Optical

Electrical Classification

Class I; Groups B, C, D; Div. 1.

Response Time

T50 < 15 seconds; T90 < 35 seconds

Clearing Time

90% < 35 seconds

Repeatability

± 3% FS

Range

0-100% (lower explosive limit) LEL

Operating Temperature

-40° to +175° F

Accuracy

± 3% FS

Sensor Warranty

5 year pro-rated

Power Consumption

Normal operation = 95 mA (2.3 watts); Full alarm = 123 mA (<3 watts)

Zero Drift

< 5% per year

Output

3 relays (alarm 1, alarm 2, and fault) contact rated 5 amps @ 250 VAC, 5 amps @ 30 VDC;
Linear 4-20 mA DC; RS-485 Modbus™

Input Voltage

22.5-28 VDC

3.4 OPERATING SOFTWARE

Operating software is menu listed with operator interface via the two magnetic program switches located under the face plate. The two switches are referred to as “PGM 1” and “PGM 2”. The menu list consists of 3 items which include sub-menus as indicated below. (Note: see the last page of this manual for a complete software flow chart.)

01. Normal Operation
 - a) Current Status

02. Calibration Mode
 - a) Zero
 - b) Span

03. Program Menu
 - a) Program Status
 - b) Alarm 1 Level
 - c) Alarm 2 Level
 - d) Calibration Level

3.4.1 Normal Operation

In normal operation, the display tracks the current status of the sensor and gas concentration and appears as: “0 % LEL”. The mA current output corresponds to the monitoring level and range of 0-100% = 4-20 mA.

3.4.2 Calibration Mode

Calibration mode allows for sensor zero and span adjustments. **“1-ZERO 2-SPAN”**

3.4.2.1 Zero Adjustment

Zero is set in ambient air with no combustible gas present or with zero gas applied to the sensor. **“AUTO ZERO”**

3.4.2.2 Span Adjustment

Unless otherwise specified, span adjustment is performed at 50% LEL methane in air. **“AUTO SPAN”**

3.4.3 Program Mode

The program mode provides a program status menu, allows for the adjustment of alarm set point levels, and the selection of the calibration gas level setting..

3.4.3.1 Program Status

The program status scrolls through a menu that displays:

- * The gas type, range of detection and software version number. The menu item appears as: “LEL 0-100 V6.0”
- * The alarm set point level of alarm 1. The menu item appears as: “ALM1 SET @ ##%”
- * The alarm firing direction of alarm 1. The menu item appears as: “ALM1 ASCENDING” or descending.
- * The alarm relay latch mode of alarm 1. The menu item appears as: “ALM1 NONLATCHING” or latching.
- * The alarm relay energize state of alarm 1. The menu item appears as: “ALM1 DE-ENERGIZED” or energized.
- * The alarm set point level of alarm 2. The menu item appears as: “ALM2 SET @ ##%”
- * The alarm firing direction of alarm 2. The menu item appears as: “ALM2 ASCENDING” or descending.
- * The alarm relay latch mode of alarm 2. The menu item appears as: “ALM2 LATCHING” or nonlatching.
- * The alarm relay energize state of alarm 2. The menu item appears as: “ALM2 DE-ENERGIZED” or energized.
- * The alarm relay latch mode of the fault alarm. The menu item appears as: “FLT NONLATCHING” or latching.
- * The alarm relay energize state of the fault alarm. The menu item appears as: “FLT ENERGIZED” or deenergized.
- * The calibration gas level setting. The menu item appears as: “CalLevel @ xx%”
- * Identification of the RS-485 ID number setting. The menu item appears as: “485 ID SET @ ##”
- * Sensor temperature in °C appears as: “TEMPERATURE xx °C”
- * The estimated remaining sensor life. The menu item appears as: “OPTICS AT 100%”

3.4.3.2 Alarm 1 Level Adjustment

The alarm 1 level is adjustable over the range 10 to 90%. For combustible gas sensors, the level is factory set at 20%. The menu item appears as: “SET ALM1 @ 20%”

3.4.3.3 Alarm 2 Level Adjustment

The alarm 2 level is also adjustable over the range 10 to 90%. For combustible gas sensors, the level is factory set at 60%. The menu item appears as: “SET ALM2 @ 60%”

3.4.3.4 Calibration Level Adjustment

The Calibration level is adjustable from 10% to 90% LEL. The menu item appears as: “CalLevel @ ##%”

3.5 INSTALLATION

Optimum performance of ambient air/gas sensor devices is directly relative to proper location and installation practice.

3.5.1 Field Wiring Table (4-20 mA output)

Detcon Model IR-622 combustible gas sensor assemblies require three conductor connection between power supplies and host electronic controllers. Wiring designators are + (DC), - (DC), and mA (sensor signal). Maximum single conductor resistance between sensor and controller is 10 ohms. Maximum wire size for termination in the sensor assembly terminal board is 14 gauge.

AWG	Meters	Feet
20	240	800
18	360	1200
16	600	2000
14	900	3000

Note 1: This wiring table is based on stranded tinned copper wire and is designed to serve as a reference only.

Note 2: Shielded cable may be required in installations where cable trays or conduit runs include high voltage lines or other sources of induced interference.

Note 3: The supply of power must be from an isolating source with over-current protection as follows:

AWG	Over-current Protection	AWG	Over-current Protection
22	3A	16	10A
20	5A	14	20A
18	7A	12	25A

The RS-485 (if applicable) requires 24 gauge, two conductor, shielded, twisted pair cable between sensor and host PC. Use Belden part number 9841. Two sets of terminals are located on the connector board to facilitate serial loop wiring from sensor to sensor. Wiring designators are **A & B** (IN) and **A & B** (OUT).

3.5.2 Sensor Location

Selection of sensor location is critical to the overall safe performance of the product. Five factors play an important role in selection of sensor locations:

- (1) Density of the gas to be detected
- (2) Most probable leak sources within the industrial process
- (3) Ventilation or prevailing wind conditions
- (4) Personnel exposure
- (5) Accessibility for routine maintenance

Density - Placement of sensors relative to the density of the target gas is such that sensors for the detection of heavier than air gases should be located within 2-4 feet of grade as these heavy gases will tend to settle in low lying areas. For gases lighter than air, sensor placement should be 4-8 feet above grade in open areas or in pitched areas of enclosed spaces.

Leak Sources - Most probable leak sources within an industrial process include flanges, valves, and tubing connections of the sealed type where seals may either fail or wear. Other leak sources are best determined by facility engineers with experience in similar processes.

Ventilation - Normal ventilation or prevailing wind conditions can dictate efficient location of gas sensors in a manner where the migration of gas clouds is quickly detected.

Personnel Exposure - The undetected migration of gas clouds should not be allowed to approach concentrated personnel areas such as control rooms, maintenance or warehouse buildings. A more general and applicable thought toward selecting sensor location is combining leak source and perimeter protection in the best possible configuration.

Note: In all installations, the sensor element in SS housing points down relative to grade (Fig. 1). Improper sensor orientation may result in false reading and permanent sensor damage.

3.5.3 Local Electrical Codes

Sensor and transmitter assemblies should be installed in accordance with all local electrical codes. Use appropriate

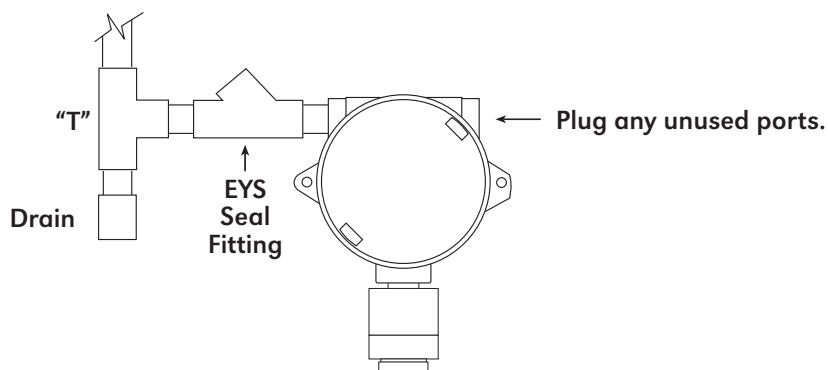

Figure #1

conduit seals. Drains & breathers are recommended. The sensor assemblies are designed to meet NEC and CSA requirements for Class I; Groups B, C, D; Div. 1 environments.

3.5.4 Accessibility

Consideration should be given to easy access by maintenance personnel as well as the consequences of close proximity to contaminants that may foul the sensor prematurely.

Note: An appropriate conduit seal must be located within 18" of the sensor assembly. Crouse Hinds type EYS2, EYD2 or equivalent are suitable for this purpose.

3.5.5 Installation Procedure

Note: See section 3.5.6 for special information on remote mounting applications in which the sensor (Model IR-622-RS) is remotely mounted away from the transmitter (Model IR-622-RT).

- Remove the junction box cover and un-plug the control circuit by grasping the two thumb screws and pulling outward.
- Securely mount the sensor junction box in accordance with recommended practice. See dimensional drawing (Fig. 2).
- Observing correct polarity, terminate 3 conductor field wiring, RS-485 wiring, and applicable alarm wiring to the sensor base connector board in accordance with the detail shown in Figure 3. Normally open and normally closed Form C dry contacts (rated 5 amp @ 120VAC; 5 amp @ 30VDC) are provided for Fault, Alarm 1, and Alarm 2.

Figure #2

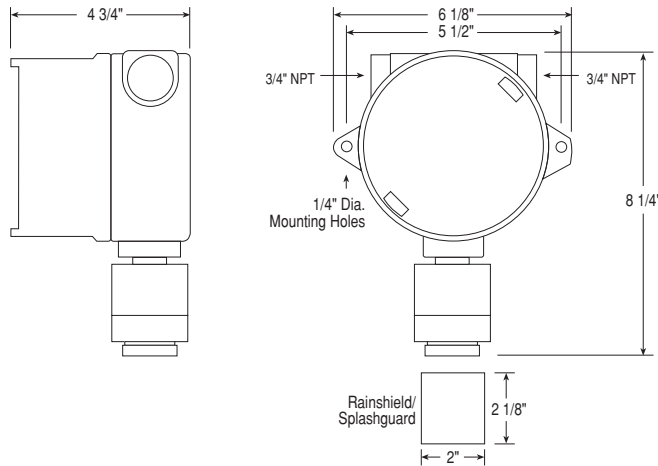

Note: Per U.L. approval, these relays may only be used in connecting to devices that are powered by the same voltages.

- Position gold plated jumper tabs located on the connector board in accordance with desired Form C dry contact outputs: NO = Normally Open; NC = Normally closed (see figure 3).

Note: If a voltage signal output is desired in place of the 4-20mA output, a 1/4 watt resistor must be installed in position R2 of the terminal board. A 250Ω resistor will provide a 1-5V output (- to mA). A 100Ω resistor will provide a .4-2V output, etc. This linear signal corresponds to 0-100% of scale (see figure 3).

- Program the alarms via the gold plated jumper tab positions located on the CPU board (see figure 4). Alarm 1 and Alarm 2 have three jumper programmable functions: latching/non-latching relays, normally energized/normally de-energized relays, and ascending/descending alarm set points. The fault alarm has two jumper programmable functions: latching/non-latching relay, and normally energized/normally de-energized relay. The default

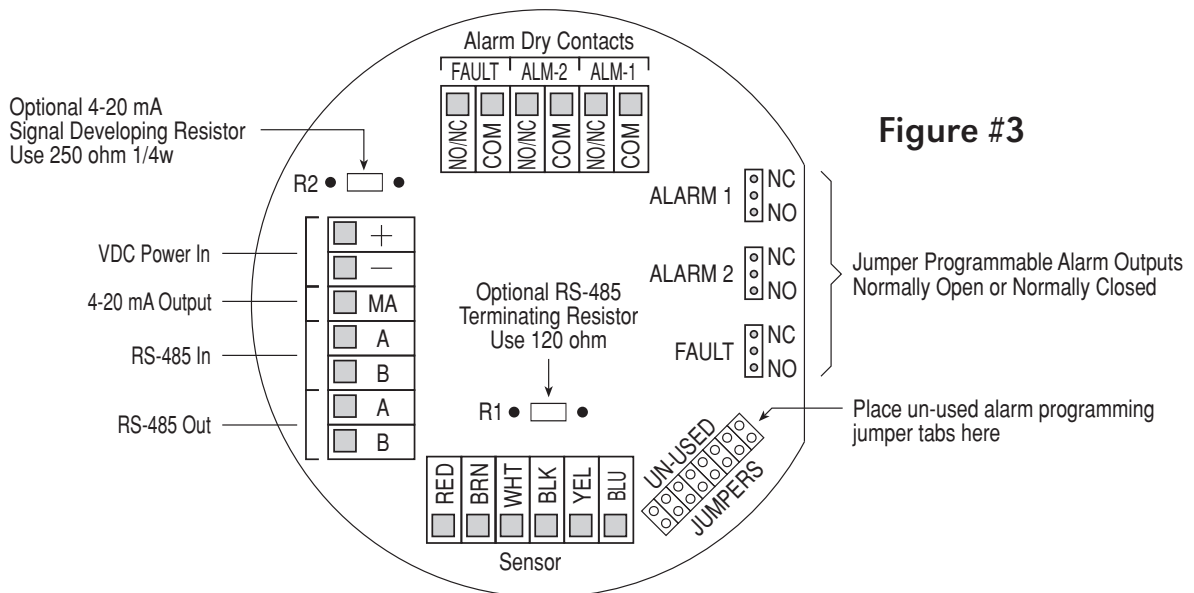

Figure #3

settings of the alarms (jumpers removed) are normally de-energized relays, non-latching relays, and alarm points that activate during descending gas conditions.

If a jumper tab is installed in the latch position, that alarm relay will be in the latching mode. The latching mode will latch the alarm after alarm conditions have cleared until the alarm reset function is activated. The non-latching mode (jumper removed) will allow alarms to de-activate automatically once alarm conditions have cleared.

If a jumper tab is installed in the energize position, that alarm relay will be in the energized mode. The energized mode will energize or activate the alarm relay when there is no alarm condition and de-energize or de-activate the alarm relay when there is an alarm condition. The de-energized mode (jumper removed) will energize or activate the alarm relay during an alarm condition and de-energize or de-activate the alarm relay when there is no alarm condition.

If a jumper tab is installed in the ascending position, that alarm relay will be in the ascending mode. The ascending mode will cause an alarm to fire when the gas concentration detected is greater than or equal to the alarm set point. The descending mode (jumper removed) will cause an alarm to fire when the gas concentration detected is lesser than or equal to the alarm set point. Except in special applications, combustible gas monitoring will require alarms to fire in **“ASCENDING”** gas conditions.

Any unused jumper tabs should be stored on the connector board on the terminal strip labeled “Unused Jumpers” (see figure 3).

- f) If applicable, set the RS-485 ID number via the two rotary dip switches located on the preamp board (see figure 5). There are 256 different ID numbers available which are based on the hexadecimal numbering system. If RS-485 communications are used, each sensor must have its own unique ID number. Use a jewelers screwdriver to set the rotary dip switches according to the hexadecimal table listed below. If RS-485 communications are not

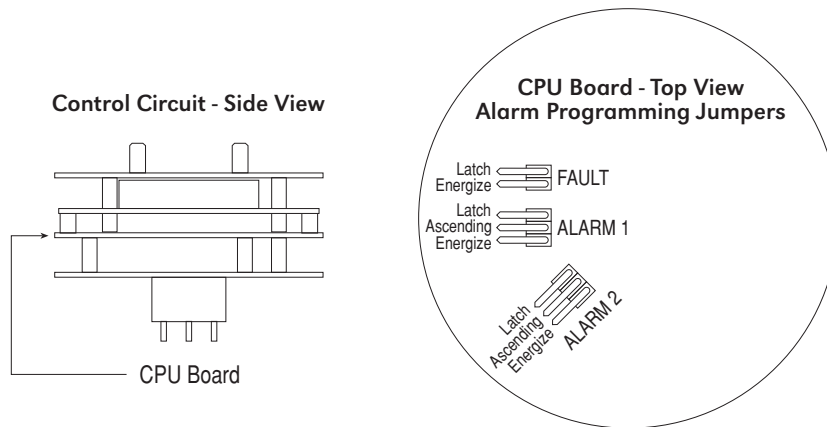

Figure #4

used, leave the dip switches in the default position which is zero/zero (0)-(0).

- g) Replace the plug-in control circuit and replace the junction box cover.

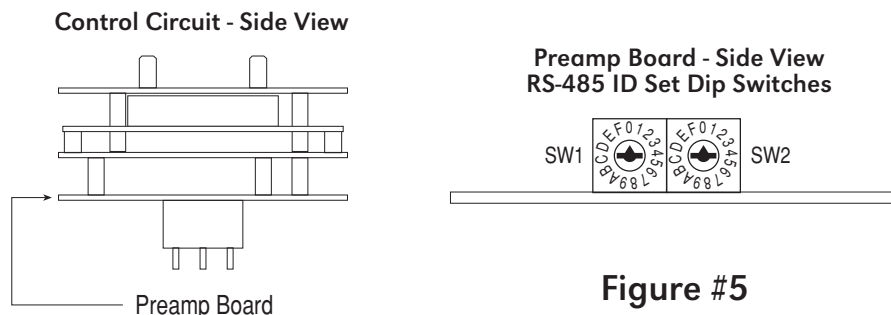

Figure #5

3.5.6 Remote Mounting Applications

ID#	SW1	SW2	ID#	SW1	SW2	ID#	SW1	SW2	ID#	SW1	SW2	ID#	SW1	SW2	ID#	SW1	SW2
none	0	0	43	2	B	86	5	6	129	8	1	172	A	C	215	D	7
1	0	1	44	2	C	87	5	7	130	8	2	173	A	D	216	D	8
2	0	2	45	2	D	88	5	8	131	8	3	174	A	E	217	D	9
3	0	3	46	2	E	89	5	9	132	8	4	175	A	F	218	D	A
4	0	4	47	2	F	90	5	A	133	8	5	176	B	0	219	D	A
5	0	5	48	3	0	91	5	B	134	8	6	177	B	1	220	D	B
6	0	6	49	3	1	92	5	C	135	8	7	178	B	2	221	D	D
7	0	7	50	3	2	93	5	D	136	8	8	179	B	3	222	D	E
8	0	8	51	3	3	94	5	E	137	8	9	180	B	4	223	E	F
9	0	9	52	3	4	95	5	F	138	8	A	181	B	5	224	E	0
10	0	A	53	3	5	96	6	0	139	8	B	182	B	6	225	E	1
11	0	B	54	3	6	97	6	1	140	8	C	183	B	7	226	E	2
12	0	C	55	3	7	98	6	2	141	8	D	184	B	8	227	E	3
13	0	D	56	3	8	99	6	3	142	8	E	185	B	9	228	E	4
14	0	E	57	3	9	100	6	4	143	8	F	186	B	A	229	E	5
15	0	F	58	3	A	101	6	5	144	9	0	187	B	B	230	E	6
16	1	0	59	3	B	102	6	6	145	9	1	188	B	C	231	E	7
17	1	1	60	3	C	103	6	7	146	9	2	189	B	D	232	E	8
18	1	2	61	3	D	104	6	8	147	9	3	190	B	E	233	E	9
19	1	3	62	3	E	105	6	9	148	9	4	191	B	F	234	E	A
20	1	4	63	3	F	106	6	A	149	9	5	192	C	0	235	E	B
21	1	5	64	4	0	107	6	B	150	9	6	193	C	1	236	E	C
22	1	6	65	4	1	108	6	C	151	9	7	194	C	2	237	E	D
23	1	7	66	4	2	109	6	D	152	9	8	195	C	3	238	E	E
24	1	8	67	4	3	110	6	E	153	9	9	196	C	4	239	F	F
25	1	9	68	4	4	111	6	F	154	9	A	197	C	5	240	F	0
26	1	A	69	4	5	112	7	0	155	9	B	198	C	6	241	F	1
27	1	B	70	4	6	113	7	1	156	9	C	199	C	7	242	F	2
28	1	C	71	4	7	114	7	2	157	9	D	200	C	8	243	F	3
29	1	D	72	4	8	115	7	3	158	9	E	201	C	9	244	F	4
30	1	E	73	4	9	116	7	4	159	9	F	202	C	A	245	F	5
31	1	F	74	4	A	117	7	5	160	A	0	203	C	B	246	F	6
32	2	0	75	4	B	118	7	6	161	A	1	204	C	C	247	F	7
33	2	1	76	4	C	119	7	7	162	A	2	205	C	D	248	F	8
34	2	2	77	4	D	120	7	8	163	A	3	206	C	E	249	F	9
35	2	3	78	4	E	121	7	9	164	A	4	207	C	F	250	F	A
36	2	4	79	4	F	122	7	A	165	A	5	208	D	0	251	F	B
37	2	5	80	5	0	123	7	B	166	A	6	209	D	1	252	F	C
38	2	6	81	5	1	124	7	C	167	A	7	210	D	2	253	F	D
39	2	7	82	5	2	125	7	D	168	A	8	211	D	3	254	F	E
40	2	8	83	5	3	126	7	E	169	A	9	212	D	4	255	F	F
41	2	9	84	5	4	127	7	F	170	A	A	213	D	5			
42	2	A	85	5	5	128	8	0	171	A	B	214	D	6			

Some sensor mounting applications require that the gas sensor head be remotely mounted away from the sensor transmitter. This is usually true in instances where the gas sensor head must be mounted in a location that is difficult to access. Such a location creates problems for maintenance and calibration activities. Detcon provides the IR-622 sensor in a remote-mount configuration in which the sensor (Model IR-622-RS) and the transmitter (Model IR-622-RT) are provided in their own conduit housing and are interfaced together with a six conductor cable. Shielded cable is required and must be installed in its own (unshared) conduit (use Alpha Wire Company #6342 cable). A maximum of 100 feet of separation is allowed. Reference figure 5A for wiring diagram.

3.6 START UP

Upon completion of all mechanical mounting and termination of all field wiring, apply system power and observe the following normal conditions:

- IR-622 “Fault” LED is off.
- A reading of 0% LEL should be indicated upon conclusion of a 12 second “warming up” cycle.

NOTE: All alarms will be disabled for 1 minute after power up. In the event of power failure, the alarm disable period will begin again once power has been restored.

Material Requirements

- * Detcon PN 3270 MicroSafe™ Programming Magnet
- * Digital volt/ohm meter.

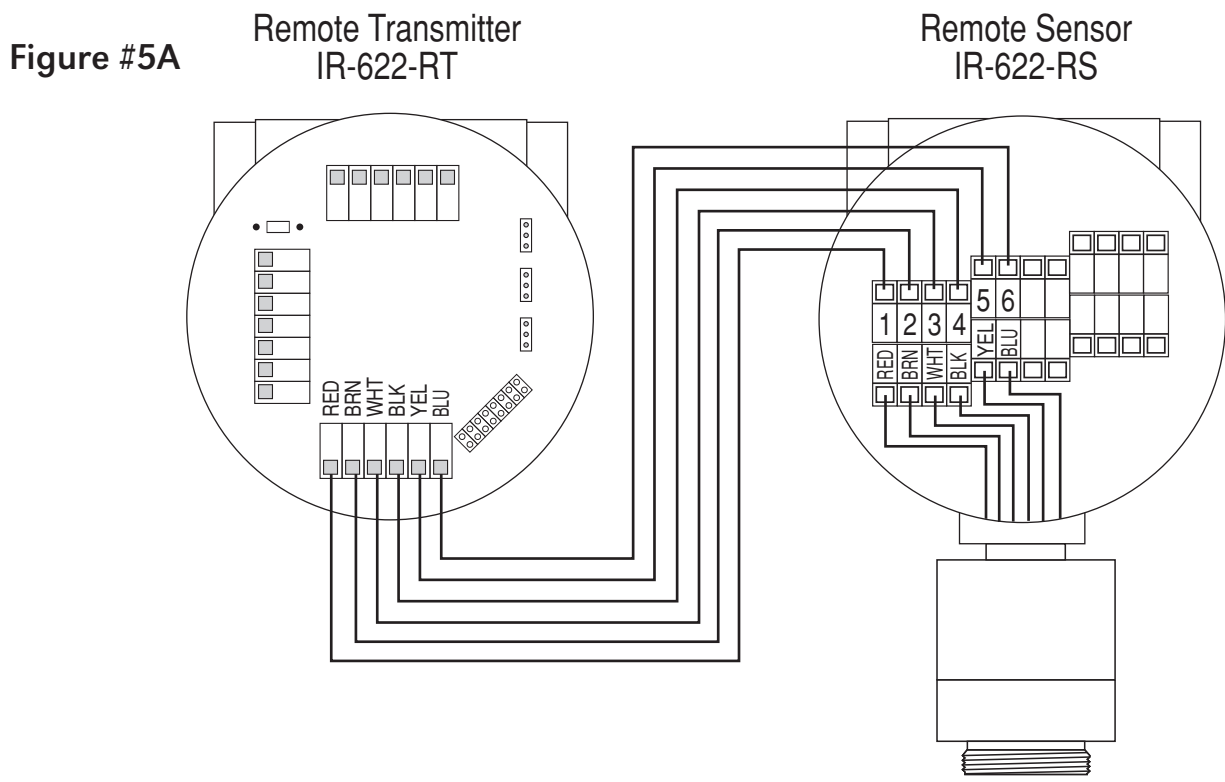

3.6.2 Programming Magnet Operating Instructions

Operator interface to MicroSafe™ gas detection products is via magnetic switches located behind the transmitter face plate. DO NOT remove the glass lens cover to calibrate or change programming parameters. Two switches labeled “PGM 1” and “PGM 2” allow for complete calibration and alarm level programming without removing the enclosure cover, thereby eliminating the need for area de-classification or the use of hot permits.

A magnetic programming tool (see figure 6) is used to operate the switches. Switch action is defined as momentary contact, 3 second hold, and 30 second hold. In momentary contact use, the programming magnet is waved over a switch location. In 3 second hold, the programming magnet is held in place over a switch location for 3 or more seconds. In 30 second hold, the programming magnet is held in place over a switch location for 30 or more seconds. Three and thirty second hold is used to enter or exit calibration and program menus while momentary contact is used to make adjustments. The location of “PGM 1” and “PGM 2” are shown in figure 7.

NOTE: If, after entering the calibration or program menus, there is no interaction with the menu items for more than 30 seconds, the sensor will return to its normal operating condition.

3.6.3 Initial Operational Tests

After a warm up period has been allowed for, the sensor should be checked to verify sensitivity to combustible

hydrocarbon gas.

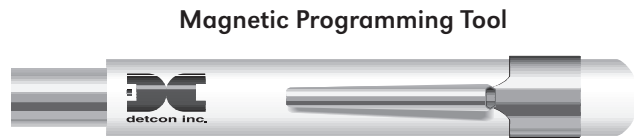

Figure #6

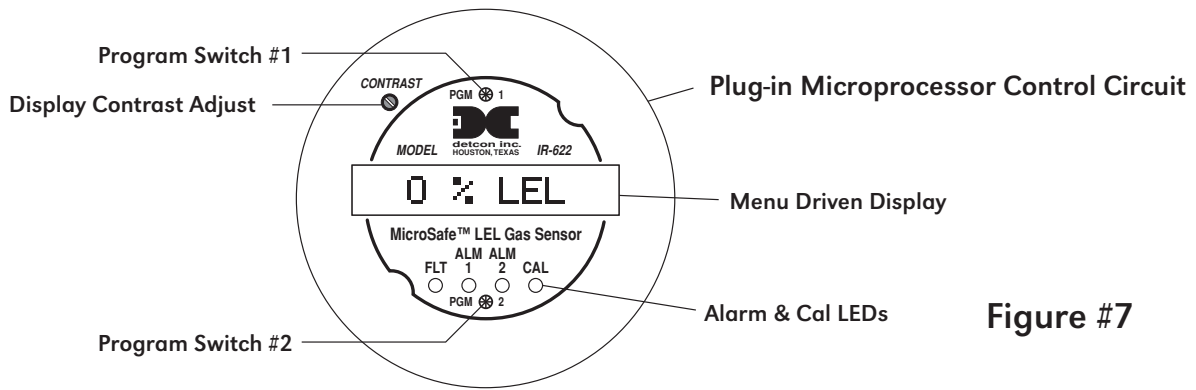

Figure #7

NOTE: If the sensor has been configured for calibration with a gas other than methane you will need to use that gas. See section 3.7 for further information on calibration gas.

Material Requirements

- * Detcon PN 6132 Threaded Calibration Adapter
 - * Span Gas 50% LEL methane in air at a controlled flow rate between 200 ml/min.
- a) Attach the calibration adapter to the threaded sensor housing. Apply a the test gas at a controlled flow rate of 200 ml/m. Observe that the LCD display increases to a level of 20% or higher.
 - b) Remove the test gas and observe that the LCD display decreases to **“0 % LEL”**.
 - c) If alarms are activated during the test, and have been programmed for latching operation, reset them according to the instructions in section 3.9.2.

Initial operational tests are complete. Detcon combustible gas sensors are pre-calibrated prior to shipment and will, in most cases, not require significant adjustment on start up. However, it is recommended that a complete calibration test and adjustment be performed within 24 hours of installation. Refer to calibration instructions in later text.

3.7 CALIBRATION

Material Requirements

- * Detcon PN 3270 MicroSafe™ Programming Magnet
- * Detcon PN 6132 Threaded Calibration Adapter
- * Span Gas containing the applicable calibration gas in air. Span gas concentration is recommended at 50% of range (which is the factory default) at a controlled flow rate of 200 ml/min. Other concentrations can be used as long as they fall within 10% to 90% of range. See section 3.7.2 for details.

3.7.1 Calibration Procedure - Zero

NOTE: Before performing a zero calibration, be sure there is no background target gas present.

- a) Enter the calibration menu by holding the programming magnet stationary over “PGM 1” (see figure 7) for 3 seconds until the display reads **“1-ZERO 2-SPAN”**, then withdraw the magnet. Note that the “CAL” LED is on.
- b) Next, enter the zero menu by holding the magnet stationary over “PGM 1” for 3 seconds until the display reads: **“ZERO 0%”**, then withdraw the magnet. The sensor has now entered the auto zero mode. When it is complete the display will read **“ZERO COMPLETE”** for 5 seconds and then return to the normal operations menu, **“0 % LEL”**.

NOTE 1: If the circuitry is unable to adjust the zero to the proper setting the sensor will enter a calibration fault mode which will cause the display to alternate between the sensor’s current status reading and the calibration fault screen which appears as: **“CAL FAULT”** (see section 3.7.3).

NOTE 2: When a “cal fault” occurs, the sensor microprocessor retains its previous calibration references. Zero calibration is complete.

3.7.2 Calibration Procedure - Span

CAUTION: Verification of the correct calibration gas level setting and calibration span gas concentration is required before “span” calibration. These two numbers must be equal.

Calibration consists of entering the calibration function and following the menu-displayed instructions. The display will ask for the application of span gas in a specific concentration. This concentration is equal to the calibration gas level setting. The factory default setting for span gas concentration is 50% LEL. In this instance, a span gas containing a concentration equal to 50% LEL is required. If a span gas containing 50% LEL is not available, other concentrations may be used as long as they fall within 10% to 90% of range. However, any alternate span gas concentration value must be programmed via the calibration gas level menu before proceeding with span calibration. Follow the instructions below for span calibration.

- a) Verify the current calibration gas level setting as indicated by the programming status menu. To do this, follow the instructions in section 3.8 and make note of the setting found in listing number 14. The item appears as “**CalLevel @ xx%**”.
- b) If the calibration gas level setting is equal to your calibration span gas concentration, proceed to item “f”. If not, adjust the calibration gas level setting so that it is equal to your calibration span gas concentration, as instructed in items “c” through “e”.
- c) Enter the programming menu by holding the programming magnet stationary over “PGM 2” for 30 seconds until the display reads “**VIEW PROG STATUS**”, then withdraw the magnet. At this point you can scroll through the programming menu by momentarily waving the programming magnet over “PGM 1” or “PGM 2”. The menu options are: View Program Status, Set Alarm 1 Level, Set Alarm 2 Level, Set Gas Factor, Set Cal Factor, and Set Cal Level.
- d) From the programming menu scroll to the calibration level listing. The menu item appears as: “**SET CAL LEVEL**”. Enter the menu by holding the programming magnet stationary over “PGM 1” for 3 seconds until the display reads “**CalLevel @ ##%**”, then withdraw the magnet. Use the programming magnet to make an adjustment to “PGM 1” to increase or “PGM 2” to decrease the display reading until the reading is equal to the desired calibration span gas concentration. Exit to the programming menu by holding the programming magnet over “PGM1” for 3 seconds.
- e) Exit back to normal operation by holding the programming magnet over “PGM 2” for 3 seconds, or automatically return to normal operation in 30 seconds.
- f) From the calibration menu “**1-ZERO 2-SPAN**” (section 3.7.1-a) proceed into the span adjust function by holding the programming magnet stationary over “PGM 2” for 3 seconds until the display reads “**APPLY xx% LEL**” then withdraw the programming magnet. The x’s here indicate the gas concentration requested.
- g) Apply the calibration gas at a flow rate of between 200 milliliters per minute. As the sensor signal changes, the display will change to “**SPAN XX%**”. The “XX” part of the reading indicates the actual gas reading which will increase until the sensor stabilizes. When the sensor signal is stable it will auto span to the request concentration and the display will change to “**SPAN COMPLETE**” for two seconds and then “**REMOVE GAS**”. Remove the gas. When the signal level has fallen below 10% of full scale, the display will return to the normal operation menu, “**0 % LEL**”.

NOTE 1: If the circuitry is unable to adjust the span to the proper setting the sensor will enter into the calibration fault mode which will cause the display to alternate between the sensor’s current status reading and the calibration fault screen which appears as: “**CAL FAULT**” (see section 3.7.3).

NOTE 2: If, after entering the span function, more than one minute elapses before calibration gas is applied, the sensor will enter the calibration fault mode which will cause the display to alternate between the sensor’s current status reading and the calibration fault screen which appears as: “**CAL FAULT**” (see section 3.7.3).

Span calibration is complete.

3.7.3 Additional Notes

1. Upon entering the calibration menu, the 4-20 mA signal drops to 2 mA and is held at this level until you return to normal operation.
2. If during calibration the sensor circuitry is unable to attain the proper adjustment for zero or span, the sensor will enter into the calibration fault mode which will activate fault alarm functions (see section 3.10) and cause the display to alternate between the sensor's current status reading and the calibration fault screen which appears as: **"CAL FAULT"**. If this occurs you may attempt to recalibrate by entering the calibration menu as described in section 3.8.1-a. If the sensor fails again, defer to technical trouble shooting.

3.7.4 Calibration Frequency

In most applications, quarterly zero calibration and annual span calibration intervals will assure reliable detection. However, industrial environments differ. Upon initial installation and commissioning, close frequency tests should be performed monthly. Test results should be recorded and reviewed to determine a suitable calibration interval.

3.8 STATUS OF PROGRAMMING, ALARMS, CALIBRATION LEVEL, RS-485 ID, TEMPERATURE, AND SENSOR LIFE

The programming menu has a programming status listing that allows the operator to view the gas, range, and software version number of the program, as well as the current alarm settings, calibration gas level setting, RS-485 ID number, sensor temperature, and estimated remaining sensor life. The programming menu also allows the calibration gas level setting (see section 3.72), and alarm levels (see section 3.9).

The following procedure is used to view the programming status of the sensor:

- a) First, enter the programming menu by holding the programming magnet stationary over "PGM 2" for 30 seconds until the display reads **"VIEW PROG STATUS"**, then withdraw the magnet. At this point you can scroll through the programming menu by momentarily waving the programming magnet over "PGM 1" or "PGM 2". The menu options are: View Program Status, Set Alarm 1 Level, Set Alarm 2 Level, and Set Cal Level.
- b) Next, scroll to the **"VIEW PROG STATUS"** listing and then hold the programming magnet over "PGM 1" for 3 seconds. The menu will then automatically scroll, at five second intervals, through the following information before returning back to the **"VIEW PROG STATUS"** listing.
 - 1 - The gas type, range of detection and software version number. The menu item appears as: **"LEL 0-100 V6.0"**
 - 2 - The alarm set point level of alarm 1. The menu item appears as: **"ALM1 SET @ 20%"**
 - 3 - The alarm firing direction of alarm 1. The menu item appears as: **"ALM1 ASCENDING"**
 - 4 - The alarm relay latch mode of alarm 1. The menu item appears as: **"ALM1 NONLATCHING"**
 - 5 - The alarm relay energize state of alarm 1. The menu item appears as: **"ALM1 DE-ENERGIZED"**
 - 6 - The alarm set point level of alarm 2. The menu item appears as: **"ALM2 SET @ 60%"**
 - 7 - The alarm firing direction of alarm 2. The menu item appears as: **"ALM2 ASCENDING"**
 - 8 - The alarm relay latch mode of alarm 2. The menu item appears as: **"ALM2 LATCHING"**
 - 9 - The alarm relay energize state of alarm 2. The menu item appears as: **"ALM2 DE-ENERGIZED"**
 - 10 - The alarm relay latch mode of the fault alarm. The menu item appears as: **"FLT NONLATCHING"**
 - 11 - The alarm relay energize state of the fault alarm. The menu item appears as: **"FLT ENERGIZED"**
 - 12 - The calibration gas level setting. The menu item appears as: **"CalLevel @ xx%"**
 - 13 - Identification of the RS-485 ID number setting. The menu item appears as: **"485 ID SET @ 1"**
 - 14 - Sensor temperature in °C appears as: **"TEMPERATURE xx °C"**
 - 15 - The estimated remaining sensor life. The menu item appears as: **"OPTICS AT 100%"**
- c) Exit back to normal operations by holding the programming magnet over "PGM 2" for 3 seconds, or automatically return to normal operation in 30 seconds.

3.9 PROGRAMMING ALARMS

3.9.1 Alarm Levels

Both alarm 1 and alarm 2 levels are factory set prior to shipment. Alarm 1 is set at 20%; alarm 2 at 60%. Both alarms can be set in 1% increments from 10 to 90%. The following procedure is used to change alarm set points:

- a) First, enter the programming menu by holding the programming magnet stationary over “PGM 2” for 30 seconds until the display reads “**VIEW PROG STATUS**”, then withdraw the magnet. At this point you can scroll through the programming menu by momentarily waving the programming magnet over “PGM 1” or “PGM 2”. The menu options are: View Program Status, Set Alarm 1 Level, Set Alarm 2 Level, and Set Cal Level.
- b) ALARM 1 LEVEL From the programming menu scroll to the alarm 1 level listing. The menu item appears as: “**SET ALARM 1 LEVEL**”. Enter the menu by holding the programming magnet stationary over “PGM 1” for 3 seconds until the display reads “**SET ALM1 @ 20%**”, then withdraw the magnet. Use the programming magnet to make an adjustment to “PGM 1” to increase or “PGM 2” to decrease the display reading until the reading is equal to the desired alarm set point. Exit to the programming menu by holding the programming magnet over “PGM1” for 3 seconds, or automatically return to the programming menu in 30 seconds.
- c) ALARM 2 LEVEL From the programming menu scroll to the alarm 2 level listing. The menu item appears as: “**SET ALARM 2 LEVEL**”. Enter the menu by holding the programming magnet stationary over “PGM 1” for 3 seconds until the display reads “**SET ALM2 @ 60%**”, then withdraw the magnet. Use the programming magnet to make an adjustment to “PGM 1” to increase or “PGM 2” to decrease the display reading until the reading is equal to the desired alarm set point. Exit to the programming menu by holding the programming magnet over “PGM1” for 3 seconds, or automatically return to the programming menu in 30 seconds.
- d) Exit back to normal operations by holding the programming magnet over “PGM 2” for 3 seconds, or automatically return to normal operation in 30 seconds.

3.9.2 Alarm Reset

An alarm condition will cause the applicable alarm to activate its corresponding relay and LED. If alarm 1, alarm 2, or fault alarms have been programmed for latching relays, an alarm reset function must be activated to reset the alarms after an alarm condition has cleared. To reset the alarms, simply wave the programming magnet over either “PGM 1” or “PGM 2”, momentarily, while in normal operations mode and note that the corresponding alarm LED(s) turn off.

3.9.3 Other Alarm Functions

Alarms are factory programmed to be non-latching, de-energized; and to fire under ascending gas conditions. The fault alarm relay is programmed as normally energized which is useful for detecting a 24VDC power source failure. All alarm functions are programmable via jumper tabs. Changing alarm functions requires the sensor housing to be opened, thus declassification of the area is required. See section 3.5.5-e for details.

3.10 PROGRAM FEATURES

Model IR-622 MicroSafe™ Sensors incorporate a comprehensive program to accommodate easy operator interface and fail-safe operation. Program features are detailed in this section. Each sensor is factory tested, programmed, and calibrated prior to shipment.

Over Range

When the sensor detects gas greater than 100% LEL, it will cause the display to flash “**100 % LEL**” on and off.

Optics Life

The Optics Life feature is a reference based on the signal output from the optical sensor. When an optical sensor life of 25% or less remains, the optical sensor should be replaced within a reasonable maintenance schedule.

Calibration Fault

If during calibration the sensor circuitry is unable to attain the proper adjustment for zero or span, the sensor will enter into the calibration fault mode and cause the display to alternate between the sensor’s current status reading and

the calibration fault screen which appears as: **“CAL FAULT.2”**.

The following conditions will cause a calibration fault:

- 1 - Zero calibration cannot converge.
- 2 - Auto span cannot converge (too noisy or too unstable).
- 3 - Span gas is not applied before 1 minute elapses.

Fail-Safe/Fault Supervision

Model IR-622 MicroSafe™ sensors are programmed for fail-safe operation. All of the fault conditions listed below will activate the fault relay, illuminate the fault LED, cause the mA output to drop to zero (0) mA, and cause the display to read its corresponding fault condition.

Memory Error

If the processor can't save values to memory, the display will indicate: **“MEMORY ERROR”**.

Zero Fault

If the sensor should drift below -10%, the display will indicate: **“ZERO FAULT”**.

Lamp Fault

If the lamp signal is lost, the display will indicate: **“LAMP FAULT.2”**.

Reference Peak High Fault

If the reference peak signal is too high (>3600), the display will indicate: **“SIGNAL FAULT.31”**.

Active Peak High Fault

If the active peak signal is too high (>3600), the display will indicate: **“SIGNAL FAULT.32”**.

Reference Peak Low Fault

If the reference peak signal is too low (<500), the display will indicate: **“SIGNAL FAULT.41”**.

Active Peak Low Fault

If the active peak signal is too low (<500), the display will indicate: **“SIGNAL FAULT.42”**.

Reference Peak to Peak Low Fault

If the reference peak to peak signal is too low (<200), the display will indicate: **“SIGNAL FAULT.51”**.

Active Peak to Peak Low Fault

If the active peak to peak signal is too low (<200), the display will indicate: **“SIGNAL FAULT.52”**.

3.11 RS-485 PROTOCOL

Detcon MicroSafe™ sensors feature Modbus™ compatible communications protocol and are addressable via rotary dip switches for multi-point communications. Other protocols are available. Contact the Detcon factory for specific protocol requirements. Communication is two wire, half duplex 485, 9600 baud, 8 data bits, 1 stop bit, no parity, with the sensor set up as a slave device. A master controller up to 4000 feet away can theoretically poll up to 256 different sensors. This number may not be realistic in harsh environments where noise and/or wiring conditions would make it impractical to place so many devices on the same pair of wires. If a multi-point system is being utilized, each sensor should be set for a different address. Typical address settings are: 01, 02, 03, 04, 05, 06, 07, 08, 09, 0A, 0B, 0C, 0D, 0E, 0F, 10, 11, etc.

In most instances, RS-485 ID numbers are factory set or set during installation before commissioning. If required, the RS-485 ID number can be set via rotary dip switches located on the preamp circuit board. However, any change to the RS-485 ID number would require the sensor housing to be opened, thus declassification of the area would be required. See section 3.5.4-f for details on changing the RS-485 ID number.

The following section explains the details of the Modbus™ protocol that the IR-622 MicroSafe™ sensor supports.

Code 03 - Read Holding Registers, is the only code supported by the transmitter. Each transmitter contains 6 holding registers which reflect its current status.

<u>Register #</u>	<u>High Byte</u>	<u>Low Byte</u>
40000	Gas type	Sensor Life

Gas type is one of the following:

01=CO, 02=H2S, 03=SO2, 04=H2, 05=HCN, 06=CL2, 07=NO2, 08=NO, 09=HCL, 10=NH3, 11=LEL, 12=O2

Sensor life is an estimated remaining use of the sensor head, between 0% and 100%

Example: 85=85% sensor life

<u>Register #</u>	<u>High Byte</u>	<u>Low Byte</u>
40001		Detectable Range

i.e. 100 for 0-100 ppm, 50 for 0-50% LEL, etc.

<u>Register #</u>	<u>High Byte</u>	<u>Low Byte</u>
40002		Current Gas Reading

The current gas reading as a whole number. If the reading is displayed as 23.5 on the display, this register would contain the number 235.

<u>Register #</u>	<u>High Byte</u>	<u>Low Byte</u>
40003		Alarm 1 Setpoint

This is the trip point for the first alarm.

<u>Register #</u>	<u>High Byte</u>	<u>Low Byte</u>
40004		Alarm 2 Setpoint

This is the trip point for the second alarm.

<u>Register #</u>	<u>High Byte</u>	<u>Low Byte</u>
40005	Status Bits	Status Bits

High Byte

Bit 7	Not used, always 0	
Bit 6	Not used, always 0	
Bit 5	Not used, always 0	
Bit 4	Not used, always 0	
Bit 3	1-Unit is in calibration	0-Normal operation
Bit 2	1-Alarm 2 is ascending	0-Alarm 2 is descending
Bit 1	1-Alarm 2 is normally energized	0-Alarm 2 is normally de-energized
Bit 0	1-Alarm 2 is latching	0-Alarm 2 is non-latching

Low Byte

Bit 7	1-Alarm 2 Relay is energized	0-Alarm 2 Relay is not energized
Bit 6	1-Alarm 1 is ascending	0-Alarm 1 is descending
Bit 5	1-Alarm 1 is normally energized	0-Alarm 1 is normally de-energized

Bit 4	1-Alarm 1 is latching	0-Alarm 1 is non-latching
Bit 3	1-Alarm 1 Relay is energized	0-Alarm 1 Relay is not energized
Bit 2	1-Fault is normally energized	0-Fault is normally de-energized
Bit 1	1-Fault is latching	0-Fault is non-latching
Bit 0	1-Fault Relay is energized	0-Fault Relay is not energized

The following is a typical Master Query for device # 8:

<u>Field Name</u>	<u>HEX</u>	<u>DEC</u>	<u>RTU</u>
Slave Address	08	8	0000 1000
Function	03	3	0000 0011
Start Address Hi	00	0	0000 0000
Start Address Lo	00	0	0000 0000
No. of Registers Hi	00	0	0000 0000
No. of Registers Lo	06	6	0000 0110
CRC	##		#### ####
CRC	##		#### ####

The following is a typical Slave Response from device # 8:

<u>Field Name</u>	<u>HEX</u>	<u>DEC</u>	<u>RTU</u>
Slave Address	08	8	0000 1000
Function	03	3	0000 0011
Byte Count	0C	12	0000 1100
Reg40000 Data Hi	02	2	0000 0010
Reg40000 Data Lo	64	100	0110 0100
Reg40001 Data Hi	00	0	0000 0000
Reg40001 Data Lo	64	100	0110 0100
Reg40002 Data Hi	00	0	0000 0000
Reg40002 Data Lo	07	7	0000 0111
Reg40003 Data Hi	00	0	0000 0000
Reg40003 Data Lo	0A	10	0000 1010
Reg40004 Data Hi	00	0	0000 0000
Reg40004 Data Lo	14	20	0001 0100
Reg40005 Data Hi	05	5	0000 0101
Reg40005 Data Lo	50	80	0101 0000
CRC	##		#### ####
CRC	##		#### ####

Additional Notes:

The calibration LED will light when the transmitter is sending a response to a Master Query. Communications are 9600 baud, 8 data bits, 1 stop bit, No parity, half duplex 485.

3.12 DISPLAY CONTRAST ADJUST

Model IR-622 MicroSafe™ sensors feature a 16 character backlit liquid crystal display. Like most LCDs, character contrast can be affected by viewing angle and temperature. Temperature compensation circuitry included in the MicroSafe™ design will compensate for this characteristic, however temperature extremes may still cause a shift in the contrast. Display contrast can be adjusted by the user if necessary. However, changing the contrast requires that the sensor housing be opened, thus declassification of the area is required.

To adjust the display contrast, remove the enclosure cover and use a jewelers screwdriver to turn the contrast adjust screw located beneath the metallic face plate. The adjustment location is marked "CONTRAST". See figure 7 for location.

3.13 OPTICAL SENSOR REPLACEMENT PROCEDURE

Should the optical gas sensor element (part number 370-365871-212) require replacement, use the following procedure:

- 1 - (A) If the sensor is mounted in a classified area, system power to the transmitter must first be removed before proceeding further.
(B) If in an unclassified area, remove front enclosure cover and unplug transmitter module.
- 2 - Remove lower half of sensor housing using an alan wrench (3 screws).
- 3 - Remove existing optical sensor and replace with new optical sensor (part number 370-365871-212).
- 4 - Re-install lower half of sensor housing.
- 5 - Restore system power (if classified) or plug in transmitter module and replace enclosure cover (if unclassified).
- 6 - As the unit reports "WARMING UP" message, use the magnetic programming tool and swipe across PGM1 or PGM2. This will take the unit into a one-time gain setting mode which takes 1 minute to complete.
- 7 - Perform a new zero calibration followed by a new span calibration (see section 3.7).

3.14 TROUBLE SHOOTING GUIDE

Calibration Faults (CalFault.2)

Calibration Faults (Zero or Span) can be cleared by successfully repeating the calibration attempt. Refer to the appropriate section in the Operator Manual and follow procedure.

Clearing Faults (Memory Error, LampFault.2, and Signal Faults.XX)

If a Fault Diagnostic occurs (Memory Error, Lamp Fault, or Signal Fault.XX) it may be a permanent problem or temporary. If it is a temporary fault, it may be cleared using the following 1) and 2) actions. If it can not be cleared then it is a permanent problem and advanced troubleshooting may be necessary.

- 1) Unplug and replug transmitters to cycle power. Determine if fault has cleared.
- 2) Re-initialize unit by unplugging and re-plugging transmitter and then immediately swiping your magnet over PGM1. The unit will go into an initializing mode and reset the optical gain settings. Observe unit as the gain setting (GN) is counted down and Ia or Ir is counted up to 2700. Record the gain set value last reported as Ia or Ir reaches 2700. Next record the final Ia and Ir values which are displayed next. Finally record the temperature which is displayed last. Determine if fault has cleared.

Normal Readings are defined below and should be recorded to discuss with Detcon Technical Service Staff:

Gain Set:55-130

Ir: 2000-2700

Ia: 1800-2700

Temp: 32C 40C (approximately 10C higher than ambient temperature)

- 3) Contact Detcon for service and repair if above mentioned troubleshooting actions have not solved problem.

Zero Fault

Zero Fault is an indication that the zero level has drifted below -10% of range.

Zero Fault can be cleared by re-calibrating zero in target gas "free" air.

Non-readable display

1. If display has blue background when hot, install sunshade to reduce temperature.
2. If poor contrast, adjust contrast pot accordingly.

Nothing Displayed – Transmitter not responding

1. Verify conduit has no accumulated water or abnormal corrosion.
2. Verify required DC power is applied to correct terminals.
3. Swap with a known-good transmitter to determine if transmitter is faulty.

Bad 4-20 mA output or RS485 Output

1. Check that wiring is connected to correct terminal outputs.
2. Swap with a known-good transmitter to determine if transmitter is faulty

Unstable output/Sudden Spiking/Nuisance Alarms

1. Check condulet for accumulated water.
2. Check transmitter and Terminal PCB for abnormal corrosion.
3. Determine if problem correlates with condensation cycles.
4. Add/change Detcon condensation prevention packet.
5. Check for unstable power supply.
6. Check for inadequate grounding.
7. If correlates with radio communications then use Detcon RFI filter accessory.
8. Contact Detcon for assistance in optimizing shielding, grounding, and RFI protection.

Excessive Span Drift or Slow Response

1. Verify correct cal gas flow rate and proper use of the cal gas adapter.
2. Check validity of cal gas via the expiration date and use pull tube if necessary.
3. Check for obstructions through s/s sinter element (including being wet).
4. Replace plug-in sensor if Optics Life is <25%.

Drifting Zero

It may be the correct reading if there are real gas leaks or the sensor was zero calibrated when actual gas was present and subsequently cleared.

1. Recalibrate zero using target gas “free” sample.
2. Replace plug-in sensor if Optics Life is <25%.

3.15 SPARE PARTS LIST

613-010000-000	Sensor rain shield
613-120000-000	Sensor splash guard
943-000006-132	Threaded Calibration Adapter
390-000087-000	IR sensor housing assembly (plug-in detector PN 370-365871-212, not included)
370-365871-212	Field replaceable NDIR optical plug in sensor
926-225500-100	IR-622 Plug-in control circuit
500-002042-000	IR Connector board
327-000000-000	Programming Magnet
897-850800-000	3 port enclosure less cover
897-850700-000	Enclosure glass lens cover
960-202200-000	Condensation prevention packet (replace annually).

3.16 WARRANTY

Detcon, Inc., as manufacturer, warrants each NDIR optical plug in sensor (part no. 370-365871-212), for a pro-rated five year period under the conditions described as follows: The warranty period begins on the date of shipment to

Figure #8

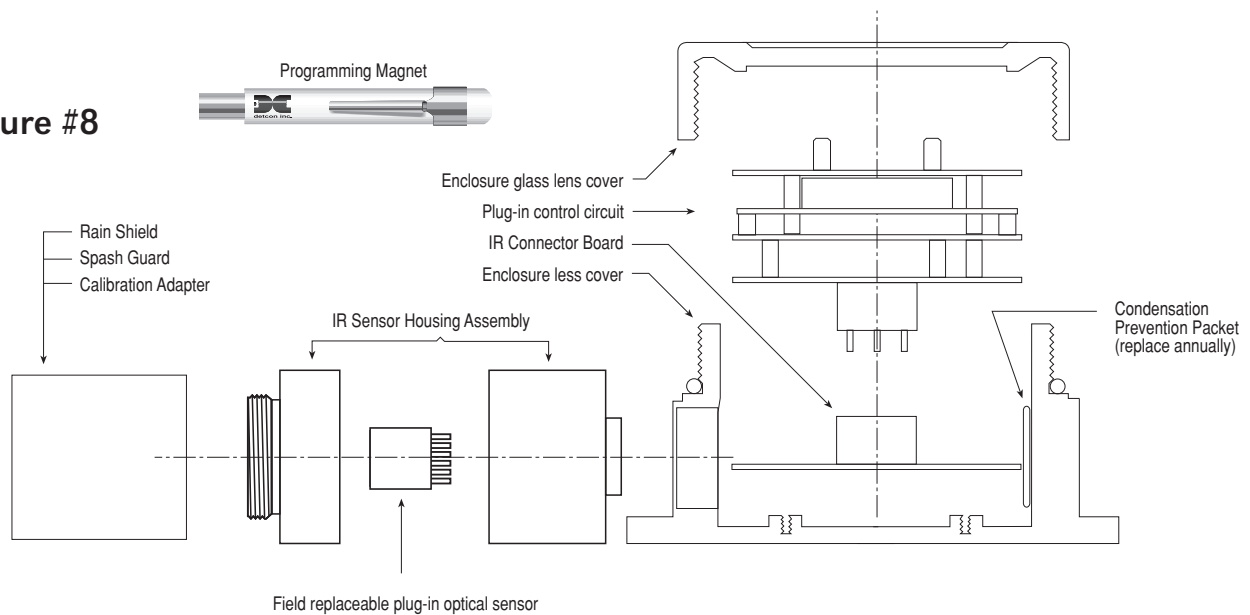

the original purchaser and ends five years thereafter. The sensor element is warranted to be free from defects in material and workmanship. Should any sensor fail to perform in accordance with published specifications within the warranty period, return the defective part to Detcon, Inc., 3200 A-1 Research Forest Dr., The Woodlands, Texas 77381, for necessary repairs or replacement.

3.17 SERVICE POLICY

Detcon, Inc., as manufacturer, warrants under intended normal use each new MicroSafe™ plug-in control circuit to be free from defects in material and workmanship for a period of two years from the date of shipment to the original purchaser. Detcon, Inc., further provides for a five year fixed fee service policy wherein any failed transmitter shall be repaired or replaced as is deemed necessary by Detcon, Inc., for a fixed fee of \$65.00. The fixed fee service policy shall affect any factory repair for the period following the two year warranty and shall end five years after expiration of the warranty. All warranties and service policies are FOB the Detcon facility located in The Woodlands, Texas.

3.18 SOFTWARE FLOW CHART

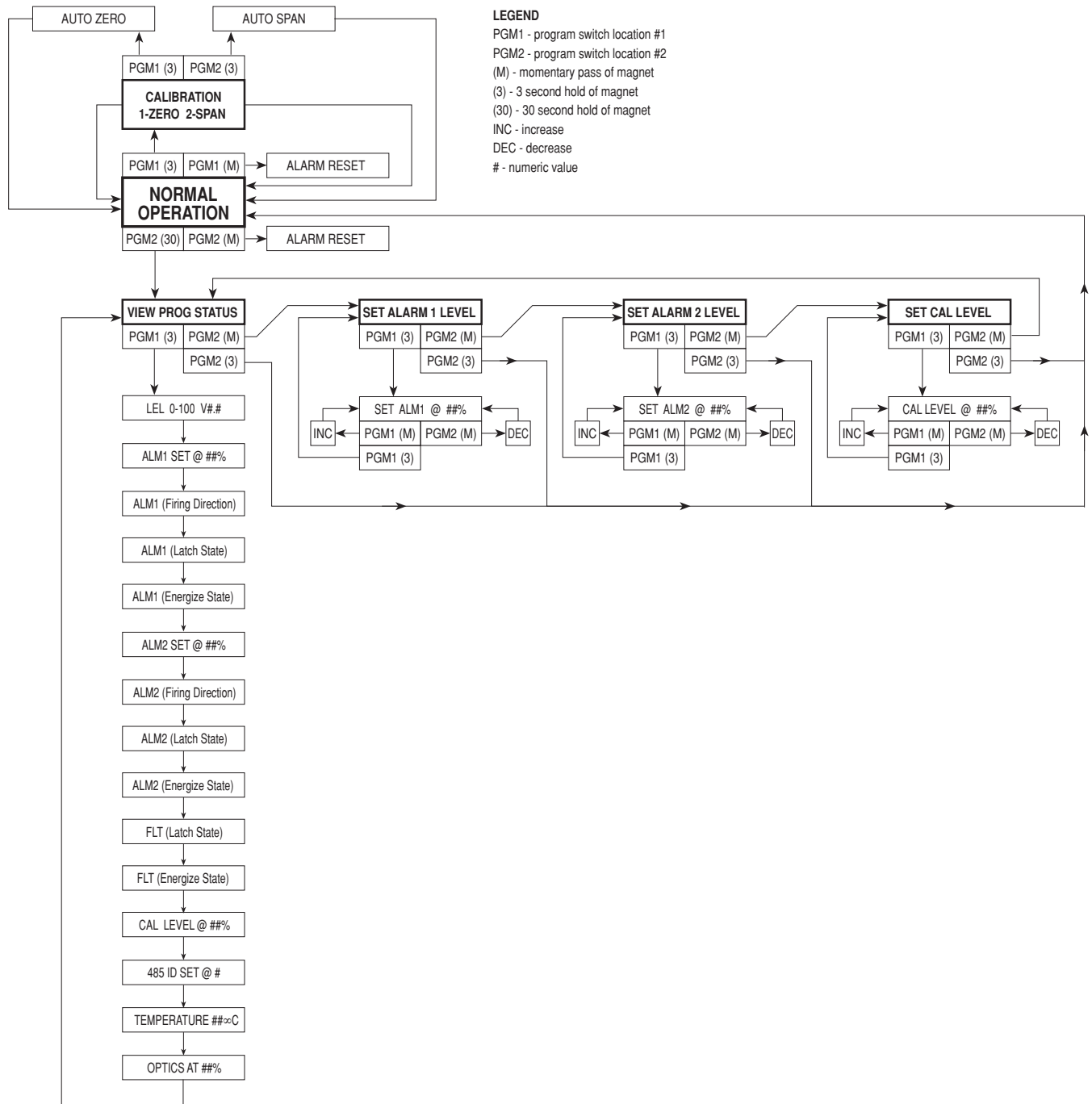

Shipping Address: 3200 A-1 Research Forest Dr., The Woodlands, Texas 7381
 Mailing Address: P.O. Box 8067, The Woodlands, Texas 77387-8067
 phone 888-367-4286, 713-559-9200 • fax 281-292-2860 • www.detcon.com • sales@detcon.com