



fill level



water level



pressure



temperature



flow



visualization



signal converter



sensoric



Precont PU4SK

Pressure transmitter for general applications

*Monitoring of absolute or relative pressure
in gases, vapors, liquids and dust*

*Technical manual
06.17*

Applications

General applications in

- Machinery and plant engineering
- Air-conditioning and refrigeration plant engineering
- Hydraulic and pneumatic systems
- Process industry
- Environmental technology
- Facility and building automation

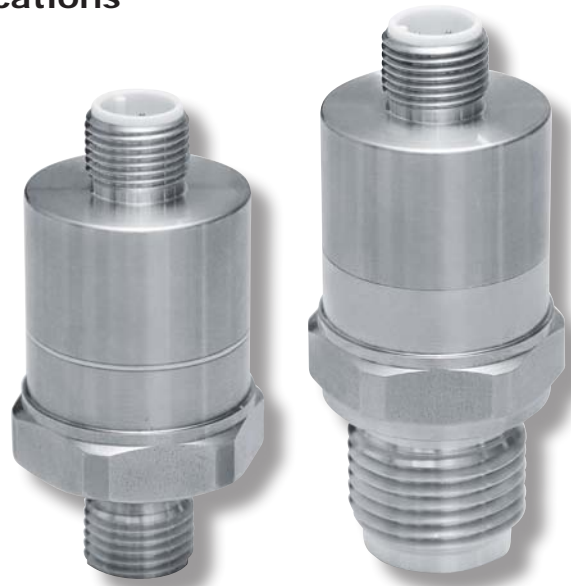

Main features

Wide range of applications

- Finely graded measuring ranges from 250 mbar up to 600 bar
- Wide process temperature range -40°C to $+135^{\circ}\text{C}$
- Wide variety of process connections
- High protection class IP69K/IP67
- Wide environmental temperature range -40°C to $+100^{\circ}\text{C}$

Ceramic front-flush or internal diaphragm

Highest accuracy – characteristic deviation to $\leq 0,15\%$ of measuring range

Integrated evaluation electronic

- Current output 4...20mA – HART® compliant (7.0)
- Digital output RS485 – Modbus RTU
- Connector plug M12

ACS-CONTROL-SYSTEM
knowledge and systems



Your partner for measuring technology and automation

You have purchased a high-grade and modern measuring device of ACS-CONTROL-SYSTEM GmbH.

We want to give thanks for your purchase and for your confidence to us.

The actual technical manual includes instructions for installation, electrical connection and inauguration, as well as the technical data of the device.

Modifications, that answer the purpose of the technical progress, are reserved by ACS-CONTROL-SYSTEM GmbH without prior notice.

If a question occurs, that can't be answered by the listed informations, please call on our technicians team in Eggenfelden Tel: +49 8721/ 9668-0 or info@acs-controlsystem.de

All rights reserved

Index

1 System description	4
1.1 Intended use	4
1.2 Field of application	4
1.3 System components	5
1.4 Function	5
2 Safety notes	6
2.1 Operational safety	6
2.2 Installation, connection, commissioning, operation	6
3 Installation	7
3.1 Installation place	7
3.2 Process and environmental temperature	7
3.3 Installation notes	7
3.4 Air pressure compensation	7
4 Electrical connection	8
4.1 Potential equalization - earthing	8
4.2 Connection cable	8
4.3 Supply voltage	8
4.4 Load resistor	8
4.5 Connection scheme	9
5 Operation	10
5.1 HART®	10
5.2 Modbus RTU	10
6 Service	11
6.1 Maintenance	11
6.2 Dismounting	11
6.3 Repair	11
6.4 Return	11
6.5 Disposal	11
7 Technical Data	12
7.1 Auxiliary power supply	12
7.2 Output	12
7.3 Measuring accuracy	12
7.4 Process conditions	13
7.5 Environmental conditions	13
7.6 Materials - process wetted	14
7.7 Materials - not process wetted	14
8 Dimension drawings	15
8.1 Terminal enclosure	15
8.2 Temperature decoupler	15
8.3 Process connection	16
9 Ordering information	19
9.1 Order code	19
9.2 Additional options	20
9.3 Accessories	20

1 System description

1.1 Intended use

The device is an electronic pressure transmitter for monitoring, control as well as continuous measurement of pressures in gases, vapors, liquids and dusts.

The operational reliability of the device is ensured only at the intended use.

1.2 Field of application

Due to the device construction with

- Measuring ranges from -1 bar to 600 bar, gauge
- Measuring ranges from 1 bar to 40 bar, absolute
- Measuring spans from 250 mbar to 600 bar
- Process temperatures from -40°C to +135°C
- Environmental temperatures from -40°C to +100°C
- Process materials Al₂O₃-ceramic / CrNi-steel

as well as the availability of industrial standard process connections like

- thread connection ISO 228-1, EN 837 manometer
- thread connection ISO 228-1, inner thread
- thread connection ISO 228-1, EN 1179-2 E
- thread connection ISO 228-1, inner bore
- thread connection ISO 228-1, front-flush

the device is especially suitable for the use for

- Machinery and plant engineering
- Air-conditioning and refrigeration plant engineering
- Hydraulic and pneumatic systems
- Process industry
- Environmental technology
- Facility and building automation

The pressure transmitter is suitable for cost sensitive as well as demanding measuring requirements.

Due to its high accuracy and the digital adjustability by HART® (7.0) or RS485 Modbus RTU, the device can be suited a wide variety of applications.

Through its optimized design, the front-flush process connection enables the cleanability of the wetted diaphragm to be integrated into the process.

The device is suitable for the use at SIP cleaning processes.

Low-maintenance and trouble-free pressure measurement is thus also guaranteed in critical applications with frequently changing media.

The robust design and the high-quality workmanship turns the device into a very high quality product, which even the most adverse environmental conditions cannot affect, whether the lowest temperatures when used outdoors, extreme shock and vibration stress or aggressive media.

A captive laser marking of the type label ensures the identifiability throughout the entire lifetime of the device.

Obviously is the optional marking of a measurement point designation resp. TAG, a customer label or of a neutral type label, of course also per laser marking.

A LABS-free resp. silicone-free version, a factory calibration with calibration certificate and a customer specific configuration resp. preset is also optionally available like a material test certificate EN10204 3.1.

Customer specific special versions can be realized short-term on request, e.g.

- extended process temperature range up to 400°C
- special designs for the process connection
 - thread connection acc. to ANSI NPT, DIN 13 or JIS
 - flange acc. to EN 1092-1/DIN 2527, ASME or JIS
 - hygienic and aseptic connections, e.g. DIN 11851, Varivent®, Clamp ISO 2852 / BS 4825 / DIN 32676, DRD, DIN 11864, DIN11853, SMS, APV-Inline, BioControl®, Aseptoflex, etc.
- other process materials, e.g. Hastelloy, Titan, PEEK, etc.
- special adjustment

1.3 System components

The device consists of the following components:

- Process connection, for installation into the wall of the container or of the pipeline.
- Pressure measuring sensor with ceramic diaphragm, as junction point in direct contact with the applied medium.
- Temperature decoupler, for decoupling of the terminal enclosure from high process temperatures.
- Terminal enclosure, for protection of the integrated signal processing electronics and for the electrical connection.

The components cannot be separated by the user.

1.4 Function

1.4.1 Measuring principle

The system pressure is directly applied to the ceramic diaphragm of the pressure measuring sensor. A dry pressure measuring sensor is used, without using a fill fluid.

The pressure dependent deflection of the diaphragm is transferred directly to a resistance measuring bridge and causes there a change of the bridge output voltage.

1.4.2 Signal processing

The pressure signal is converted by the pressure measuring sensor into an electrical signal and processed by the integrated evaluation electronics according to the respective preferences:

1.4.2.1 Electronic output – 2-wire, current 4...20mA, HART® compliant

- The measuring value is converted into a continuous current signal 4...20mA.
- The digital HART® conformal FSK communication signal is coupled onto the signal current.
- All settings can be adjusted comfortably and easily by a HART® operation unit or a PC with an operating program.
- The HART® protocol is based on a Master-Slave-Architecture.

1.4.2.2 Electronic output – 4-wire, RS485, Modbus RTU

- The measuring value is transmitted over a bidirectional digital interface RS485.
- All settings can be adjusted by this interface.
- The RS485 interface uses the communication protocol Modbus RTU, which has found its way into industrial communication as an open protocol.
- The Modbus protocol is based on a Master-Slave-Architecture, where up to 247 slaves can be controlled by one master.

2 Safety notes

2.1 Operational safety

The device is safely built and tested according to state-of-the-art technology and has left the factory in perfect condition as regards technical safety.

The device meets the legal requirements of all relevant EU directives. This is confirmed by attaching the CE mark.

This measuring device meets article 4 (3) of the EU directive 2014/68/EU (pressure equipment device directive) and is designed and produced in good engineer practice.

Devices with measurement end value > 200 bar are constructed for media of fluid group 2.

2.2 Installation, connection, commissioning, operation

Installation, electrical connection, commissioning and operation of the device must be made by a qualified and authorized expert according to the information's in this technical manual and the relevant standards and rules. This expert must have read and understood this technical manual and especially the safety notes.

The device may only be used within the permitted operation limits that are listed in this technical manual. Every use besides these limits as agreed can lead to serious dangers.

The materials of the device must be checked for compatibility with the respective application requirements (contacting materials, process temperature) before use. An unsuitable material can lead to damage, abnormal behavior or destruction of the device and to the resulting dangers.

The sensors may not be used as sole device for prevention of dangerous conditions in machines and plants.

Using the device in a manner that does not fall within the scope of its intended use, disregarding this instruction, using under-qualified personnel, or making unauthorized alterations releases the manufacturer from liability for any resulting damage. This renders the manufacturer's warranty null and void.

3 Installation

The correct function of the device within the specific technical data can only be guaranteed, if the permitted process and environmental temperatures (see chapter „Technical data“) will not be exceeded.

3.1 Installation place

The installation of the device at locations where high pressure blows can occur should be avoided.

At a pressure measurement in gases, the device should be installed above the tapping point, so that the condensate can flow into the process.

At a pressure measurement in steams, the device should be installed after a siphon and a shut-off device below the tapping point.

The siphon reduces the temperature to almost ambient temperature.

Fill the siphon with fluid before commissioning.

At a pressure measurement in liquids, the device should be installed after a shut-off device below or at the same level as the tapping point.

At a filling level measurement in liquids, the device should be installed below the lowest measuring point. Do not mount the device in the fill flow, in the suction area of a pump, in the tank outlet or at a point in the container which could be affected by pressure pulses from an agitator. Calibration and functional test can be carried out more easily if you mount the device after a shut-off device.

The installation position can have an influence on the measuring result of the kind of a zero value shift because of the deadweight of the measuring diaphragm. The correction of this deviation at the device is possible.

3.2 Process and environmental temperature

The installation of the device should be made if possible at temperature calmed places to get a reliable measuring result.

Strong temperature steps, e.g. at filling of a hot liquid into a cold system, can produce a short-time higher measuring signal deviation.

At high process temperatures a heat transfer to the terminal enclosure can be reduced by isolation of the medium carrying part of the plant.

3.3 Installation notes

Drive the system pressure free prior installation resp. deinstallation of the sensor.

The protective cap, which is attached at the diaphragm, must only be removed immediately before the installation.

The diaphragm must not be point loaded, because this can lead to diaphragm damage.

The installation of the device into a closed off completely with process liquid filled connection can lead to destruction of the measuring diaphragm. The reduction of the volume of the liquid at screw-in leads to a very high pressure boosting, which can exceed the permitted maximum value by a multiple. Thus, before installation, the connection must be sufficiently emptied.

The screw-in of the thread process connection by using the terminal enclosure, the connection plug resp. the connection cable is not permitted.

The tightening of the thread process connection may only be done at the hexagon by a suitable spanner and with the maximum permitted torque strength (see chapter „Technical data“).

3.4 Air pressure compensation

Avoid the damaging or pollution of the pressure compensation system.

The hindrance of the pressure compensation can lead to faulty measuring results.

The filter element of the pressure compensation system is positioned at the side of the enclosure.

4 Electrical connection

The electrical connection of the device must be carried out according to the respective country specific standards.

Incorrect installation or adjustment could cause applicationally conditioned risks.

4.1 Potential equalization - earthing

The device must be grounded.

The earthing can be carried out by the process connection.

4.2 Connection cable

Use only shielded signal and measurement wires and install these wires separated from power leading wires.

Connect the cable shield of a connected cable only at one side to earth, ideally at the installation place of the device.

4.3 Supply voltage

The voltage applied to the terminal contacts may not exceed the maximum permitted supply voltage (see chapter „Technical data“) to avoid damage of the electronic. The connection is reverse polarity protected.

4.4 Load resistor

4.4.1 Electronic output – 2-wire, current 4...20mA

A load resistor, e.g. the measuring shunt of an evaluation device, requires a minimum supply voltage [U_{Smin}]. Dependent on the connected supply voltage [U_s], it results in a maximum value for this resistor [R_{Lmax}], where a correct function is still possible.

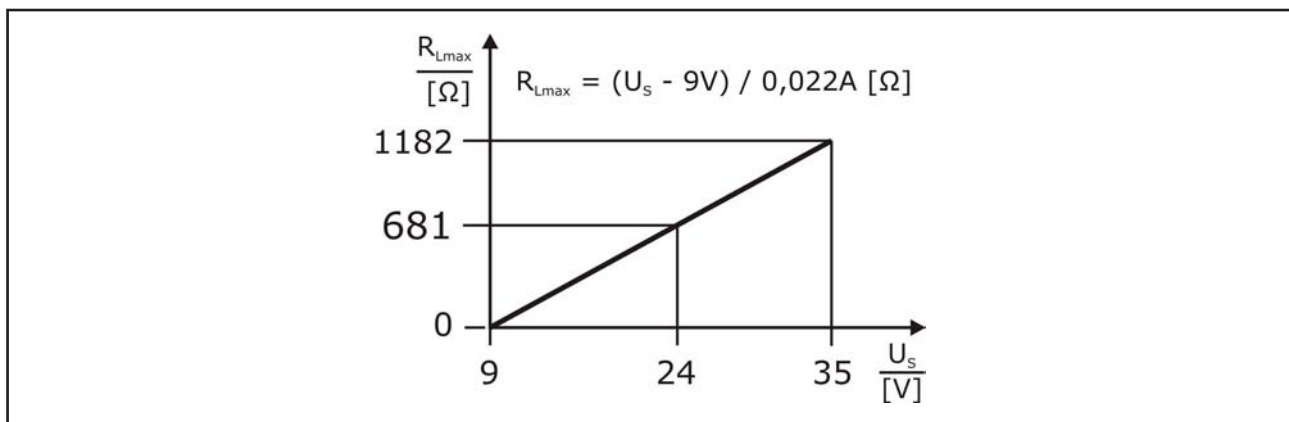

4.5 Connection scheme

4.5.1 Electronic output – 2-wire, current 4...20mA

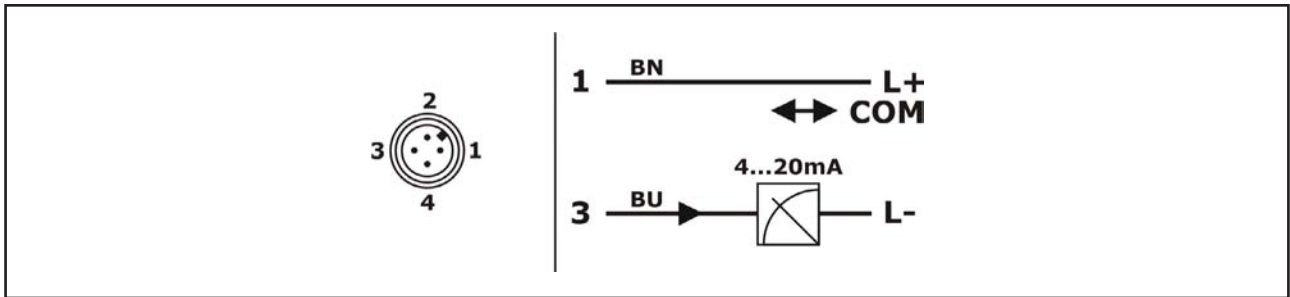

Conductor color standard connection cable M12 – A-coded:

BN = brown, BU = blue

For the HART® communication by a HART® interface a minimum communication resistance of 250Ω has to be taken into account.

4.5.2 Electronic output – 4-wire, RS485

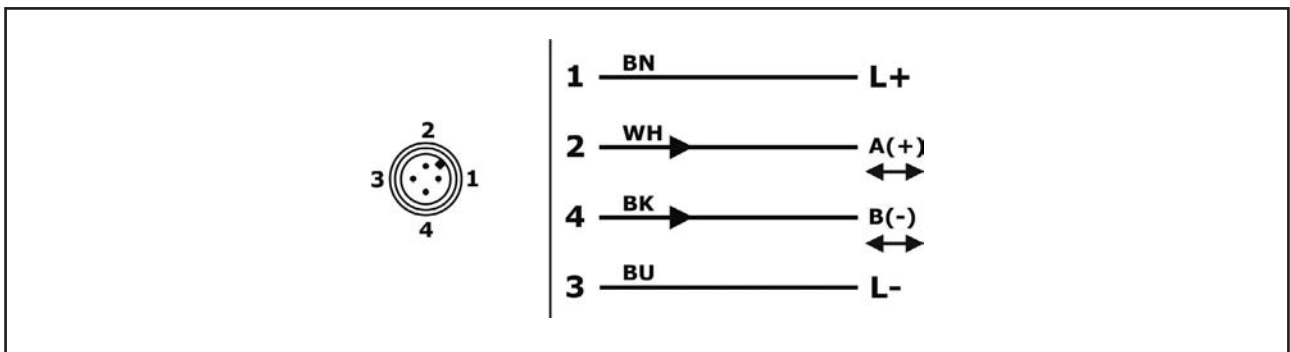

Conductor color standard connection cable M12 – A-coded:

BN = brown, WH = white, BU = blue, BK = black

5 Operation

By several adjustable parameters, the device can be customized optimally to the given application:

- Adjustment zero value / end value
- Damping
- TAG

The readability of the device parameter allows additionally an easy documentation of the measuring point.

5.1 HART®

After power-up of the supply voltage the device can be connected for minimum 20s per HART® communication.

If a system damping $t_d = 0s \dots < 1s$ is set, the parameterization mode will be left after 20s and a new HART® communication is only possible after a new power-up of the supply voltage. If a HART® communication has taken place within these 20s, the parameterization mode will be left automatically after a time of inactivity of 4 minutes. By this also a fast measuring sensor can be parameterized per HART® communication.

At a system damping $t_d \geq 1s$ a HART® communication can always take place, a deactivation will not happen.

The default setting for the system damping is $t_d = 0s$.

The parameter setting of the device is made by a HART® operation unit or a Windows-PC with a configuration software in combination with a standard HART® interface.

As configuration software a general configuration software, e.g. PACTware™ and a suitable device driver (DTM), e.g. ICS Generic HART DTM acc. to FDT standard can be used.

A HART® operation unit, e.g. E+H Field Xpert allows an easy field operation.

5.2 Modbus RTU

In preparation

6 Service

6.1 Maintenance

The device is free of maintenance.

Special substances can lead to solid coatings on the sensor. Seized depositions can lead to faulty measurement results.

In the case of coat forming liquids the sensor must be regularly cleaned e.g. with clear water. Don't use sharp resp. hard tools or aggressive chemicals for cleaning.

6.2 Dismounting

Attention – Risk of burns!

Let the device cool down sufficiently fore dismounting it

During dismounting there is a risk of dangerously hot media escaping.

Attention – Risk of injury!

Dismount the device only when the system is pressureless.

During dismounting there is a risk of fast escaping media resp. pressure blow.

6.3 Repair

A repair may only be carried out by the manufacturer.

If the device is sent back for repair, the following information's must be enclosed:

- An exact description of the application.
- The chemical and physical characteristics of the product.
- A short description of the occurred error.

6.4 Return

Before returning the device, the following measures must be performed:

- All adhesive product residues must be removed. This is especially important, if the product is unhealthily, e.g. caustic, toxic, carcinogenic, radioactive etc.
- A returning must be refrained, if it is not possible by 100% to remove the unhealthily product completely, because e.g. it is penetrate into cracks or is diffused through plastic.

6.5 Disposal

Dispose of instrument components and packaging materials in an environmentally compatible way and in accordance with the country-specific waste disposal regulations.

This instrument is not subject to the WEEE directive and the respective national laws. Hence, pass the instrument directly on to a specialized recycling company and do not use the municipal collecting points. These may be used only for privately used products according to the WEEE directive.

7 Technical Data

7.1 Auxiliary power supply

Supply voltage U_s	9...35V _{DC} , reverse polarity protected
Residual ripple U_{pp}	$\leq 2V_{pp} / U_{Smin} \leq U_s \leq U_{Smax}$
Supply current I_{in}	<i>Electronic output type A – 2-wire, current 4...20mA</i> $\leq 22mA$
	<i>Electronic output type V – 4-wire, RS485</i> $\leq 10mA$

7.2 Output

7.2.1 Analogue output – current 4...20mA – HART® compliant

Operating range I_{out}	3,9...21mA, min. 3,8mA, max. 22mA
Permitted load R_l	$\leq (U_s - 9V) / 22mA$
Step response time T_{90}	$\leq 8ms$ ($t_d = 0s$)
Start-up time t_{on}	$\leq 0,2s$ ($t_d = 0s$)

Communication	FSK modulated current signal – HART® compliant (7.0)
Signal	$\pm 0,5mA - 1200Hz / 2200Hz$
Communication resistor	$\geq 250\Omega$, external
Activity	20s ($t_d = 0...<1s$) ∞ ($t_d = \geq 1s$)
Address	0 (0...15)
Transmission rate	1200 Bit/s

7.2.2 Digital output – RS485 – Modbus RTU

Interface	RS485, bidirectional
Signal	Digital – Modbus RTU
Address	001 (001...247)
Transmission rate	9600 Baud (4800 / 9600 / 19200 / 38400)
Parity	Odd (None / Odd / Even)
Step response time T_{90}	$\leq 8ms$ ($t_d = 0s$)
Start-up time t_{on}	$\leq 0,1s$ ($t_d = 0s$)

7.3 Measuring accuracy

Reference conditions	EN/IEC 60770-1	
	Environmental temperature	15...25°C
	Environmental air pressure	860..1060kPa
	Air humidity	45...75% r.h.
	Warm-up time t_{on}	240s
	Supply voltage U_s	24V _{DC} $\pm 0,1V$
	Calibration position	Vertical Process connection bottom

Characteristic deviation ^{3) 5) 6) 12)}	$\leq \pm 0,15\% / \pm 0,5\% FS$ ²⁾
Nonlinearity+ Hysteresis ^{6) 12)}	$\leq \pm 0,05\% / \pm 0,4\% FS$ ²⁾
Repeatability ^{6) 12)}	$\leq \pm 0,1\% FS$ ²⁾
Influence of supply voltage	$\leq \pm 0,002\% FS$ ²⁾ / V
Long term drift ^{6) 12)}	$\leq \pm 0,2\% FS$ ²⁾ / year
Temperature deviation ^{6) 12)}	T_k ⁴⁾ <i>Zero+ Span</i> $\leq \pm 0,05\% FS$ ²⁾ / K
Mounting position ¹⁰⁾	$\leq 0,2$ mbar

²⁾ Referring to nominal measuring span resp. full scale (FS)

³⁾ Nonlinearity + Hysteresis + Reproducibility

⁴⁾ T_k = Temperature coefficient

⁵⁾ Limit value adjustment acc. to EN/IEC 60770-1

⁶⁾ Specification for $TD^{7)} = 1$ (adjusted measuring range = nominal measuring range).

Specification for $TD^{7)} \geq 1$ (adjusted measuring range \leq nominal measuring range) = specification at nominal measuring range $\times TD^{7)}$

⁷⁾ Turn-Down $TD = \text{nominal measuring range (FS}^{2)}) / \text{adjusted measuring range}$

¹⁰⁾ Device rotated by 180°, process connection upside

¹²⁾ Higher values for special measuring range

7.4 Process conditions

Process temperature	-40°C...+100°C
The permitted range results from the narrowest limitation of standard range resp. extended range.	<u>Extension</u> Temperature decoupler -40°C...+135°C (+140°C – 1h)
	<u>Limitation</u> Gasket - FPM -25°C...+200°C Gasket - EPDM -40°C...+140°C

Process pressure	Pressure range	Over/Burst pressure	Vacuum
[R] Gauge pressure	-1...0 bar [R]	3 bar / 8 bar	0 bar [A]
[A] Absolute pressure	-1...+1 bar [R]	6 bar / 12 bar	0 bar [A]
<u>Limitation</u> depending on process connection	0...250 mbar [R]	750 mbar / 2,5 bar	0 bar [A]
	0...400 mbar [R]	1,2 bar / 4 bar	0 bar [A]
	0...600 mbar [R]	1,8 bar / 6 bar	0 bar [A]
	0...1 bar [R/A]	3 bar / 8 bar	0 bar [A]
	0...1,6 bar [R/A]	6 bar / 12 bar	0 bar [A]
	0...2,5 bar [R/A]	6 bar / 12 bar	0 bar [A]
	0...4 bar [R/A]	15 bar / 20 bar	0 bar [A]
	0...6 bar [R/A]	15 bar / 20 bar	0 bar [A]
	0...10 bar [R/A]	20 bar / 40 bar	0 bar [A]
	0...16 bar [R/A]	40 bar / 80 bar	0 bar [A]
	0...25 bar [R/A]	40 bar / 80 bar	0 bar [A]
	0...40 bar [R/A]	100 bar / 200 bar	0 bar [A]
	0...60 bar [R]	100 bar / 200 bar	0 bar [A]
	0...100 bar [R]	200 bar / 400 bar	0 bar [A]
	0...160 bar [R]	400 bar / 800 bar	0 bar [A]
	0...250 bar [R]	400 bar / 800 bar	0 bar [A]
0...320 bar [R]	800 bar / 1000 bar	0 bar [A]	
0...400 bar [R]	800 bar / 1000 bar	0 bar [A]	
0...600 bar [R]	900 bar / 1000 bar	0 bar [A]	

7.5 Environmental conditions

Environmental temperature	-40°C...+100°C
Protection	IP69K/IP67 (EN/IEC 60529)
Climatic classification	4K4H (EN/IEC 60721-3-4)
Shock classification	50g [11ms] (EN/IEC 60068-2-27)
Vibration classification	20g [10...2000 Hz] (EN/IEC 60068-2-6)
EM compatibility	Operation device class B / Industrial range (EN/IEC 61326)
Tightening torque	$\leq 50\text{Nm}$
Weight	0,2kg

7.6 Materials - process wetted

Membrane	Ceramic aluminum oxide Al ₂ O ₃ – 96%
Process connection	Steel 1.4404/316L
Gaskets	FPM – fluorelastomere (e.g. Viton®) EPDM – ethylene-propylene-dienmonomere, FDA-listed

7.7 Materials - not process wetted

Terminal enclosure	CrNi-steel
Electrical connection part	Device plug PUR
Pressure compensation element	Acrylic copolymer
Gaskets	FPM – fluorelastomere (e.g. Viton®)

8 Dimension drawings

8.1 Terminal enclosure

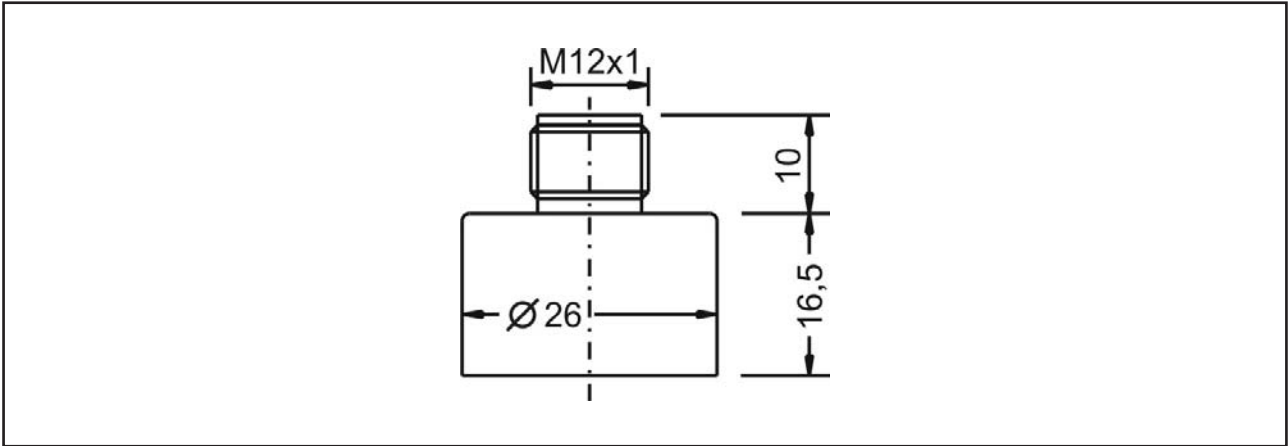

8.2 Temperature decoupler

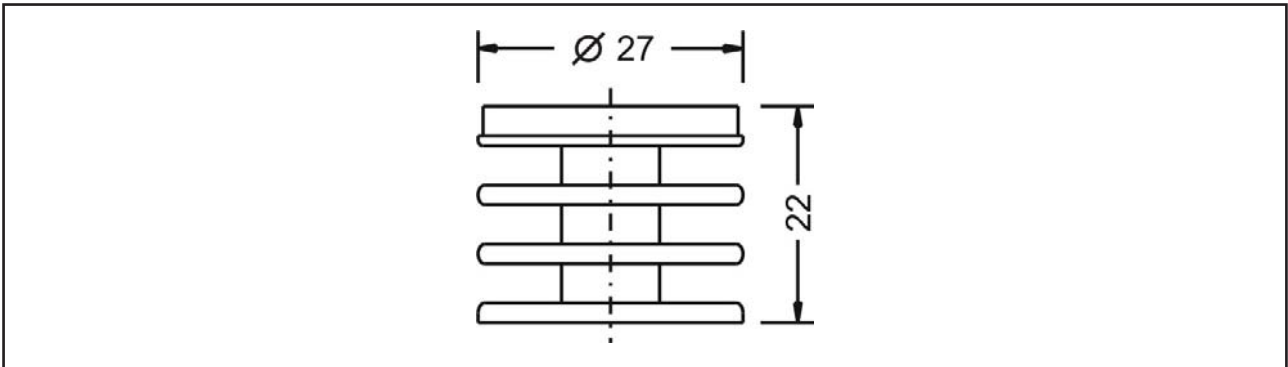

8.3 Process connection

8.3.1 Internal process membrane

Type 6 – Thread ISO 228-1 – G $\frac{1}{4}$ "A, EN 837

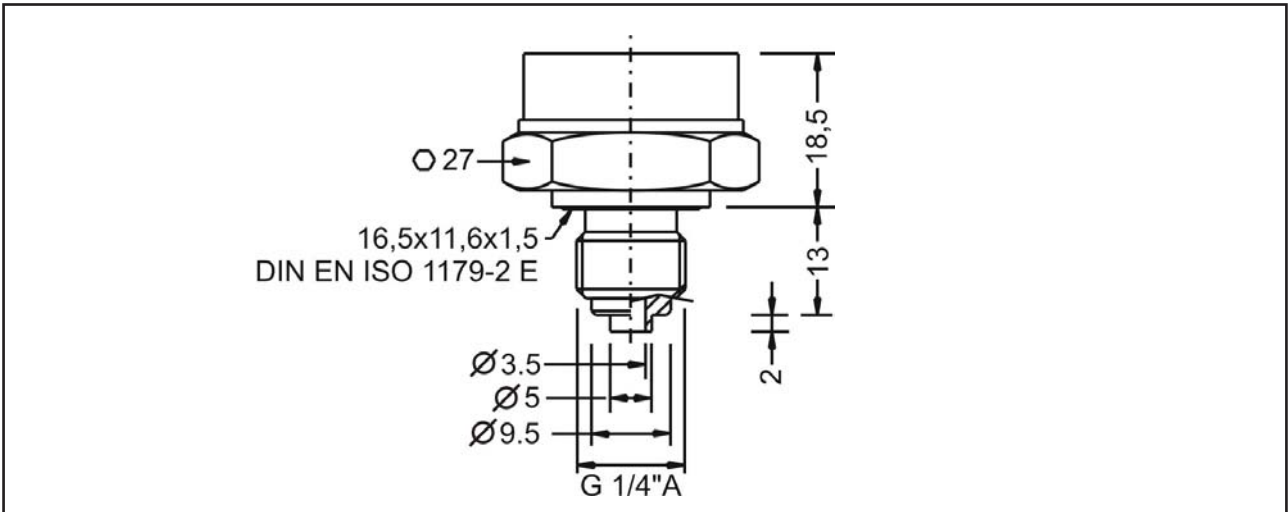

Type 1 – Thread ISO 228-1 – G $\frac{1}{2}$ "A, EN 837

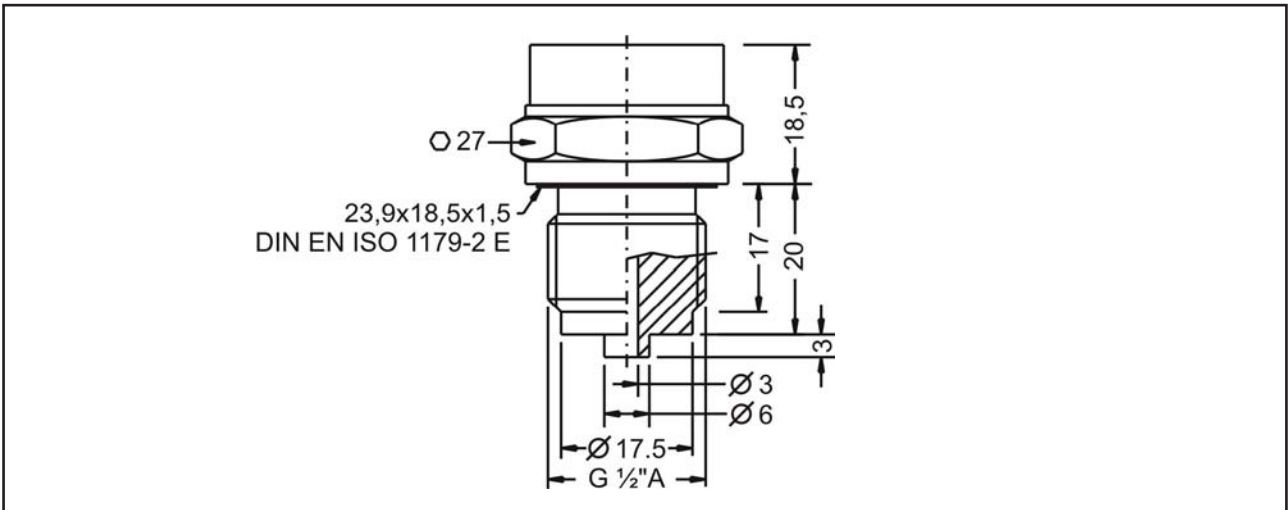

Type 3 – Thread ISO 228-1 – G $\frac{1}{4}$ "A, DIN EN ISO 1179-2 E

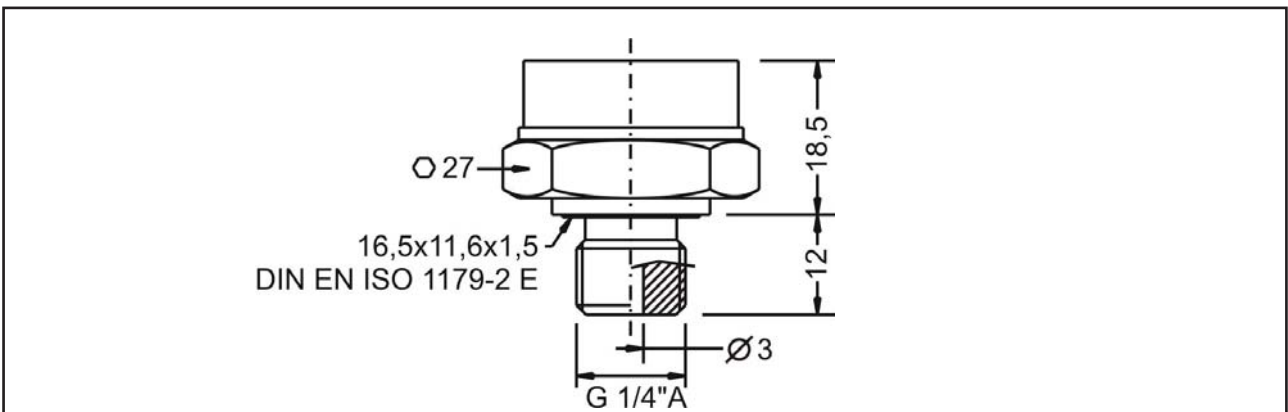

Type 4 – Thread ISO 228-1 – G $\frac{1}{4}$ " I, inner thread

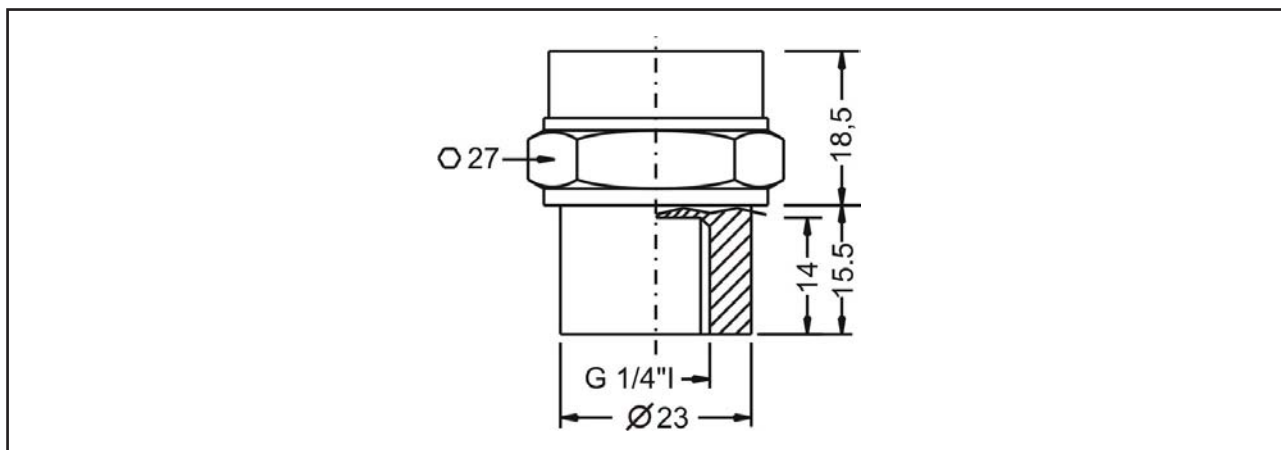

Type 2 – Thread ISO 228-1 – G $\frac{1}{2}$ " A, DIN EN ISO 1179-2 E, inner bore

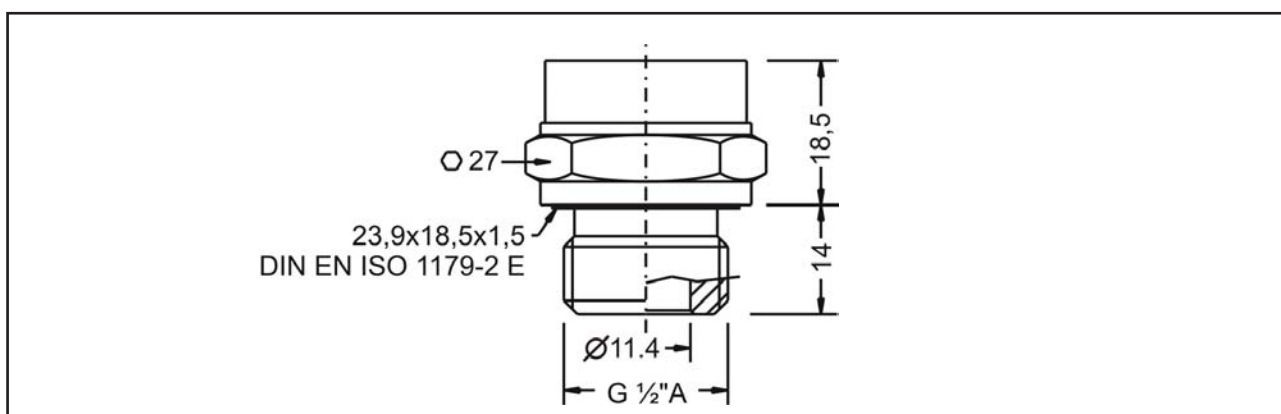

8.3.2 Front-flush process membrane

Type 8 – Thread ISO 228-1 – G $\frac{3}{4}$ "A, front-flush

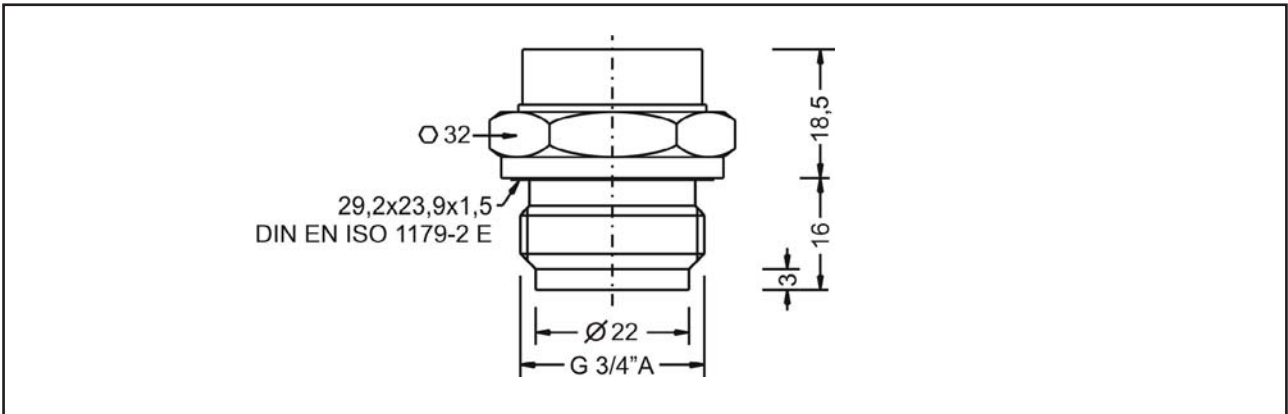

Type 5 – Thread ISO 228-1 – G1"A, front-flush

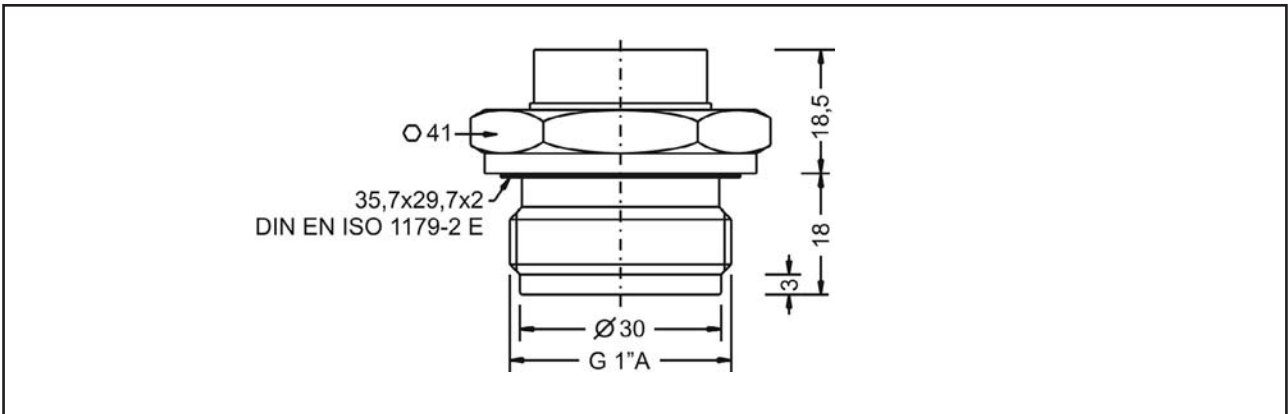

9 Ordering information

9.1 Order code

<p>Type PU4S Standard</p> <p>Measuring system – material diaphragm (process wetted) / sensor type Ceramic Al₂O₃ 96% / strain gauge</p> <p>Approval S Standard</p> <p>Process connection 6 Thread ISO 228-1 – G¼”A, EN 837 manometer 1 Thread ISO 228-1 – G½”A, EN 837 manometer 3 Thread ISO 228-1 – G¼”A, DIN EN ISO 1179-2 E 4 Thread ISO 228-1 – G¼”I, inner thread 2 Thread ISO 228-1 – G½”A, DIN EN ISO 1179-2 E, inner bore 8 Thread ISO 228-1 – G¾”A, front-flush, ≤ 10 bar 5 Thread ISO 228-1 – G1”A, front-flush, ≤ 1 bar Y others</p> <p>Material process gaskets (process wetted) 1 FPM – fluorelastomere (e.g. Viton®) 3 EPDM – ethylene-propylene-dienmonomere, FDA-listed Y others</p> <p>Material process connection (process wetted) V CrNi-steel</p> <p>Material terminal enclosure C CrNi-steel</p> <p>Measuring range 02 0...250 mbar 03 0...400 mbar 04 0...600 mbar 05 0...1 bar 06 0...1,6 bar 07 0...2,5 bar 08 0...4 bar 09 0...6 bar 10 0...10 bar 11 0...16 bar 12 0...25 bar 13 0...40 bar 14 0...60 bar 19 0...100 bar 20 0...160 bar 21 0...250 bar 22 0...320 bar 23 0...400 bar 24 0...600 bar 16 -1...0 bar 17 -1...+1 bar YY Special measuring range</p> <p>Electronic – output A 2-wire, current 4...20mA, HART® compliant V 4-wire, RS485, Modbus RTU</p> <p>Electronic – function S Standard</p> <p>Process temperature 0 Standard -40°C...+100°C 1 Extended -40°C...+135°C, temperature decoupler</p> <p>Pressure type R Gauge pressure A Absolute pressure, ≥ 1bar ... ≤ 40bar</p> <p>Measuring system – accuracy 4 0,5% 8 Xcellence – 0,15%, linearization protocol</p> <p>Electrical connection S Plug M12x1</p>	<p>K</p> <p>S</p> <p>V</p> <p>C</p> <p>S</p> <p>S</p>
--	---

Precont®

PU4S
K
S
V
C
S
S

9.2 Additional options

For the device additional options are available.

The respective abbreviation subsequently follows the order code.

- SF LABS-free, silicone-free / paint compatible version
- ML Measurement point designation / TAG – Laser marking
- KL Customer label on device – Laser marking
- TN Type label neutral
- MZ Material test certificate – EN10204 3.1
- WT Factory certification – drink water suitability
- WL Factory certification – food suitability
- KF Configuration / Preset
- WK Factory calibration – calibration certificate

9.3 Accessories

Accessories are not content of delivery of the device and must be ordered separately.

9.3.1 Installation material

A wide range of accessories for device installation is constantly available, e.g.

- Welding sockets
- Welding flanges
- Blind flanges
- Flanges with thread
- Reductions
- Tube nuts
- Siphons
- Marking plate measuring point, laser marked
- etc.

9.3.2 Connection cable / Cable box

Connection cable M12x1, material PUR, shielded

- LKZ04##PUR-AS 4-pole, straight, ## = length 2...30m
- LKW04##PUR-AS 4-pole, angled, ## = length 2...30m

Other connection cables, e.g. other material or unshielded are available.

Cable box M12x1

- BKZ0412-VA 4-pole

ACS-CONTROL-SYSTEM
knowledge and systems

Your partner for measuring technology and automation



ACS-CONTROL-SYSTEM GmbH
Lauterbachstr. 57
D- 84307 Eggenfelden

Tel.: +49 (0) 8721/ 9668-0
Fax: +49 (0) 8721/ 9668-30

info@acs-controlsystem.de
www.acs-controlsystem.de