

# INSTRUCTION MANUAL

## Detcon Model TP-700

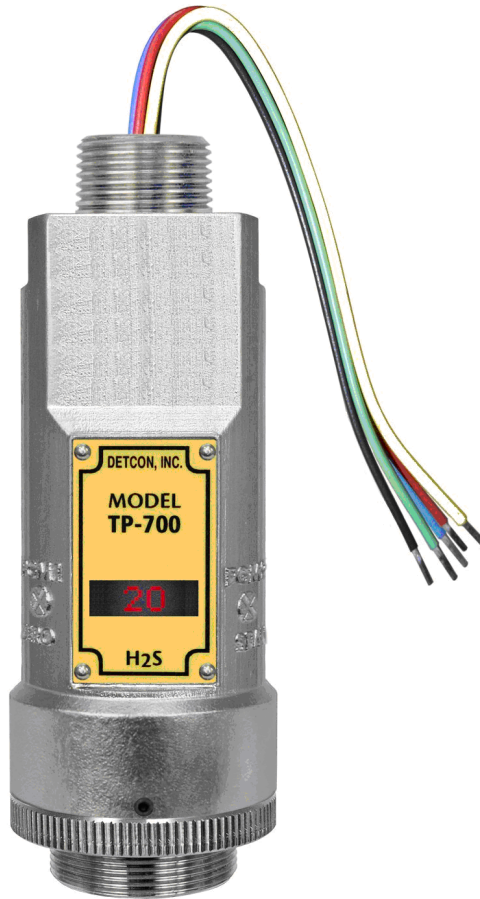

### TP-700 Hydrogen Sulfide Sensor

This manual covers the following ranges:  
0-20ppm, 0-50ppm, 0-100ppm and 0-200ppm



◆ DETCON, Inc.

4055 Technology Forest Blvd.,  
The Woodlands, Texas 77381  
Ph.281.367.4100 / Fax 281.298.2868

[www.detcon.com](http://www.detcon.com)

This page left intentionally blank

## Table of Contents

1.	Introduction .....	1
1.1	Description.....	1
1.2	Sensor Electronics Design .....	1
1.3	Modular Mechanical Design.....	2
1.4	Plug-in Replaceable Sensor .....	3
2.	Installation .....	4
2.1	ATEX Operational Guidelines for Safe Use.....	4
2.2	Sensor Placement .....	5
2.3	Sensor Contaminants and Interference .....	6
2.4	Mounting Installation.....	7
2.5	Electrical Installation .....	8
2.6	Field Wiring .....	9
2.7	Initial Start Up.....	10
2.7.1	Initial Operational Tests .....	11
3.	Operation .....	12
3.1	Programming Magnet Operating Instructions.....	12
3.2	Operator Interface .....	13
3.3	Normal Operation .....	14
3.4	Calibration Mode (AutoSpan).....	15
3.5	Program Mode .....	17
3.5.1	Navigating Program Mode .....	17
3.5.2	View Sensor Status.....	18
3.5.3	Set AutoSpan Level.....	19
3.5.4	Set Range.....	19
3.5.5	Set Serial ID .....	20
3.5.6	Set Heater Power .....	20
3.5.7	Signal Output Check.....	21
3.5.8	Restore Factory Defaults .....	21
3.6	Program Features .....	22
3.6.1	Operational Features.....	22
3.6.2	Fault Diagnostic/Failsafe Features .....	22
4.	RS-485 Modbus™ Protocol .....	25
	Content Description.....	25
5.	Service and Maintenance.....	27
5.1	Calibration Frequency.....	27
5.2	Visual Inspection .....	27
5.3	Condensation Prevention Packet.....	27
5.4	Replacement of Plug-in H <sub>2</sub> S Sensor .....	27
5.5	Replacement of ITM.....	28
5.6	Replacement of TP-700 Sensor Assembly.....	29
5.7	Replacement of the Bottom Housing.....	29
6.	Troubleshooting Guide.....	30
7.	Customer Support and Service Policy .....	33
7.1	Warranty Notice.....	33
8.	TP-700 Sensor Warranty .....	34
8.1	Plug-in H <sub>2</sub> S Sensor Warranty .....	34
8.2	ITM Electronics Warranty .....	34
8.3	Terms & Conditions.....	34
9.	Appendix .....	35
9.1	Specifications.....	35

9.2	Spare Parts, Sensor Accessories, Calibration Equipment .....	37
9.3	Model TP-700 Engineering Drawings .....	38
10.	Revision Log .....	38

## Table of Figures

Figure 1	ITM Circuit Functional Block Diagram.....	2
Figure 2	Sensor Assembly Front View .....	2
Figure 3	Sensor Assembly Breakaway.....	3
Figure 4	TP Plug-in Sensor Cell.....	3
Figure 5	ATEX Approval Label.....	4
Figure 6	Outline and Mounting Dimensions .....	7
Figure 7	Typical Installation .....	8
Figure 8	Sensor Wire Connections.....	10
Figure 9	Magnetic Programming Tool .....	12
Figure 10	Magnetic Programming Switches .....	12
Figure 11	TP-700 Software Flowchart .....	14
Figure 12	Sensor Assembly.....	27
Figure 13	Sensor PCB .....	30

## List of Tables

Table 1	Cross Interference Gases .....	6
Table 2	Wire Gauge vs. Distance .....	9

# 1. Introduction

## 1.1 Description



Detcon Model TP-700 hydrogen sulfide sensors are non-intrusive “Smart” sensors designed to detect and monitor H<sub>2</sub>S in air. Ranges of detection are 0-20ppm, 0-50ppm, 0-100ppm, and 0-200ppm. The sensor features an LED display of current reading, fault and calibration status. The Sensor is equipped with standard analog 4-20mA and Modbus™ RS-485 outputs. A primary feature of the sensor is its method of automatic calibration, which guides the user through each step via fully scripted instructions displayed on the LED display.

The microprocessor-supervised electronics are packaged in an encapsulated module and housed in an explosion proof casting, called the ITM (Intelligent Transmitter Module). The ITM includes a four character alpha/numeric LED used to display sensor readings, and the sensor’s menu driven features when the hand-held programming magnet is used.

### Solid State H<sub>2</sub>S Sensor Technology

The sensor technology is a patented solid-state mixed metal oxide semiconductor. The sensor consists of two thin films, a temperature sensitive heater film, and a hydrogen sulfide sensitive sensor film. Both films are deposited on a silicon microchip by vacuum deposition. The heater film elevates the operating temperature of the sensor film to a level where a good sensitivity and response to hydrogen sulfide is achieved. The sensor film is a proprietary mixed metal oxide that shows an extremely stable and dynamic response to hydrogen sulfide gas.

Range of sensitivity is from parts per billion to percent by volume. The rugged sensor is capable of maintaining its operating characteristics for periods of up to 7-10 years in most industrial environments and as such, is supported by a 10-year conditional warranty.

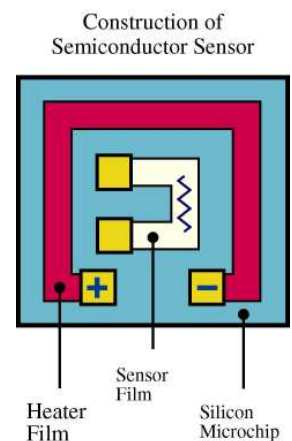

### Principle of Operation

Method of detection is by diffusion/adsorption. Air and H<sub>2</sub>S diffuse through a sintered stainless steel filter (flame arrestor) and contact the heated surface of the metal oxide sensor film. As hydrogen sulfide gas molecules react with oxygen ions on the film, there is a decrease in electrical resistance proportional to the gas concentration. The heater film elevates the temperature of the sensor film creating convection and promoting a quick response to changing gas concentrations. Electronically, the heater film is used to maintain a constant temperature of the sensor film enhancing stability and repeatability. The sensor response is reversible and results in continuous monitoring of ambient air conditions.

## 1.2 Sensor Electronics Design

### Intelligent Sensor Module

The Intelligent Transmitter Module (ITM) is a fully encapsulated microprocessor-based package that accepts a plug-in field replaceable H<sub>2</sub>S sensor. Circuit functions include extensive I/O circuit protection, sensor pre-amplifier, sensor temperature control, on-board power supplies, microprocessor, LED display, magnetic programming switches, a linear 4-20mA DC output, and a Modbus™ RS-485 output. Magnetic program switches located on either side of the LED Display are activated via a hand-held magnetic programming tool,

thus allowing non-intrusive operator interface with the ITM. Calibration can be accomplished without declassifying the area. Electrical classifications are Class I, Division 1, Groups B, C, D and Class I, Zone 1, Group IIB+H<sub>2</sub>.

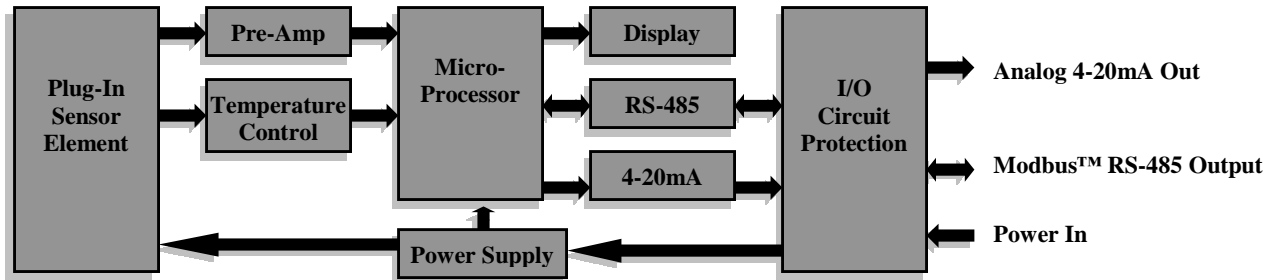

Figure 1 ITM Circuit Functional Block Diagram

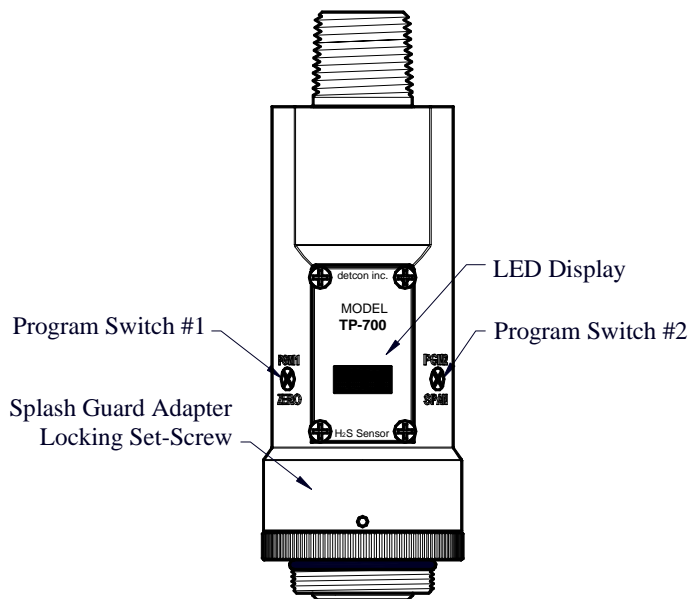

Figure 2 Sensor Assembly Front View

### 1.3 Modular Mechanical Design

The Model TP-700 Sensor Assembly is completely modular and is made up of four parts (See Figure 3 for Assembly Break-away):

- 1) TP-700 Intelligent Sensor Module (ITM)
- 2) Field Replaceable Plug-in H<sub>2</sub>S Gas Sensor
- 3) Model 700 Housing Bottom Assembly (contains the Housing Bottom, Flame Arrestor, Retaining Ring, and rubber O-Ring's)
- 4) Splash Guard.

NOTE: All metal components are constructed from electro polished 316 Stainless Steel in order to maximize corrosion resistance in harsh environments.

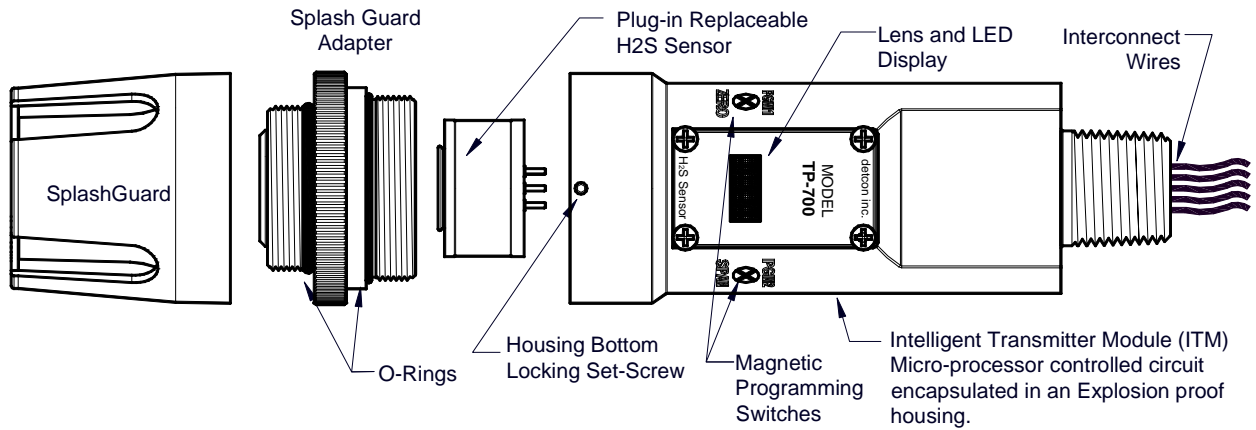

**Figure 3** Sensor Assembly Breakaway

## 1.4 Plug-in Replaceable Sensor

The Detcon solid-state  $H_2S$  gas sensor is a field proven, plug-in replaceable type sensor with over-sized gold-plated connections that eliminate corrosion problems. It can be accessed and replaced in the field very easily by releasing the locking screw and unthreading the housing bottom. The Detcon solid state  $H_2S$  sensor has an infinite shelf life and is supported by a 10 year, industry-leading warranty.



**Figure 4** TP Plug-in Sensor Cell

## 2. Installation

### 2.1 ATEX Operational Guidelines for Safe Use

1. Install sensor only in areas with classifications matching with those described on the ATEX approval label. Follow all warnings listed on the label.

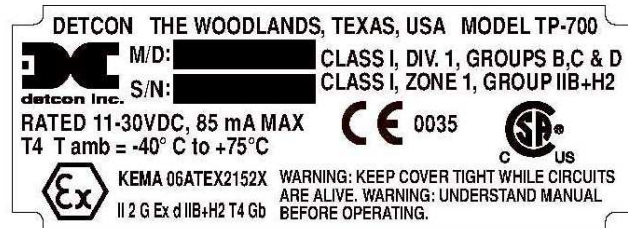

Figure 5 ATEX Approval Label

2. Ensure that the sensor is properly threaded into a suitable explosion-proof rated junction box with a downward pointing female  $\frac{3}{4}$ " NPT threaded connection. The sensor should be threaded up at least 5 full turns until tight, with the LED display facing forward. Avoid use of Teflon Tape, or any type of non-conductive pipe thread coating on the NPT threaded connection.
3. A good ground connection should be verified between the sensor's metal enclosure and the junction box. If a good ground connection is not made, the sensor can be grounded to the junction box using the sensor's external ground lug. Also verify a good ground connection between the junction box and earth ground. Installer shall use ring terminal to make connection to earth ground to be secured by screw and lockwasher on sensor housing.
4. Ensure that the Housing Bottom and plug-in sensor are installed during operation. The Housing Bottom should be threaded tightly to the Intelligent Transmitter Module. The locking setscrew (M3.5 x 0.6 6g6h Stainless Steel Allen set screw cup point with yield strength of greater than 40,000 PSI, typical 80,000 PSI) should then be tightened down to keep the Housing Bottom from being inadvertently removed or from becoming loose under vibration. The locking setscrew ensures that Housing Bottom is only removable by authorized personnel with the use of special tools. A M1.5 Allen Wrench is required. If screw requires replacement, only an identical screw may be used.
5. Removal of the Housing Bottom violates the Ex d protection method and hence power must be removed from the sensor prior its safe removal.
6. The screws holding down the retaining plate label are special fasteners of type Stainless Steel, Phillips Pan-head Machine screw, M3 x 0.5 6g6h having yield strength of greater than 40,000 PSI, typical 80,000 PSI. If screw requires replacement, only an identical screw may be used.
7. Proper precautions should be taken during installation and maintenance to avoid the build-up of static charge on the plastic components of the sensor. These include the splashguard and splashguard adapter.
8. Do not operate the sensor outside of the stated operating temperature limits.
9. Do not operate the sensor outside the stated operating limits for voltage supply.
10. These sensors meet EN60079-0:2009, EN60079-1:2007.



## 2.2 Sensor Placement

Selection of sensor location is critical to the overall safe performance of the product. Five factors play an important role in selection of sensor locations:

- (1) Density of the gas to be detected
- (2) Most probable leak sources within the industrial process
- (3) Ventilation or prevailing wind conditions
- (4) Personnel exposure
- (5) Maintenance access
- (6) Additional Placement Considerations

### Density

Placement of sensors relative to the density of the target gas is such that sensors for the detection of heavier than air gases should be located within 4 feet of grade as these heavy gases will tend to settle in low lying areas. For gases lighter than air, sensor placement should be 4-8 feet above grade in open areas or in pitched areas of enclosed spaces.

---

**Note:** H<sub>2</sub>S is heavier than air.

---

### Leak Sources

The most probable leak sources within an industrial process include flanges, valves, and tubing connections of the sealed type where seals may either fail or wear. Other leak sources are best determined by facility engineers with experience in similar processes.

### Ventilation

Normal ventilation or prevailing wind conditions can dictate efficient location of gas sensors in a manner where the migration of gas clouds is quickly detected.

### Personnel Exposure

The undetected migration of gas clouds should not be allowed to approach concentrated personnel areas such as control rooms, maintenance or warehouse buildings. A more general and applicable thought toward selecting sensor location is combining leak source and perimeter protection in the best possible configuration.

### Maintenance Access

Consideration should be given to providing easy access for maintenance personnel. Consideration should also be given to the consequences of close proximity to contaminants that may foul the sensor prematurely.

---

**NOTE:** In all installations the gas sensor should point straight down (refer to Figure 7). Improper sensor orientation may result in false readings and permanent sensor damage.

---

### Additional Placement Considerations

The sensor should not be positioned where it may be sprayed or coated with surface contaminating substances. Painting sensor assemblies is prohibited.

Although the sensor is designed to be RFI resistant, it should not be mounted in close proximity to high-powered radio transmitters or similar RFI generating equipment.

When possible mount in an area void of high wind, accumulating dust, rain or splashing from hose spray, direct steam releases, and continuous vibration. If the sensor cannot be mounted away from these conditions then make sure the Detcon Harsh Environment Splashguard accessory is used.

Do not mount in locations where temperatures will exceed the operating temperature limits of the sensor. Where direct sunlight leads to exceeding the high temperature-operating limit, use a sunshade to help reduce temperature.

## 2.3 Sensor Contaminants and Interference

Solid State H<sub>2</sub>S sensors may be adversely affected by exposure to certain airborne substances. Loss of sensitivity or corrosion may be gradual if such materials are present in sufficient concentrations.

The more common materials that potentially cause problems with the sensors are as follows:

- Silicone vapors such as those found in greases and lubricants
- Halide Compounds containing Chlorine, Chlorine Dioxide, Fluorine, HF, HCl, and Bromine
- Caustic and Acid liquids and concentrated vapors
- Heavy metals such as tetraethyl lead

The presence of such contaminants in an area does not preclude the use of this H<sub>2</sub>S sensor technology, although it is likely that the sensor lifetime will be shorter as a result. Use of this sensor in these environments may require more frequent calibration checks to ensure safe system performance.

Solid State H<sub>2</sub>S sensors require O<sub>2</sub> in the background gas and the reading is affected by changing O<sub>2</sub> levels.

### Interference Data

There are some gases typically found in industrial environments that can cause a cross-interference response on the sensor. See the Table below for some examples.

**Table 1** Cross Interference Gases

GAS	PPM	GAS	PPM
Methane	25,000 = 0	Ammonia	500 = 1
Ethane	5,000 = 0	Diesel Fuel	1000 = 0
Hexane	5,000 = 0	Dimethyl Sulfide	4.4 = 0
Propane	5,000 = 0	Ethylene	200 = 0
Butane	5,000 = 0	Freon 12	1,000 = 0
Carbon Monoxide	800 = 0	Hydrogen	1,000 = 8
Carbon Dioxide	5,000 = 0	Methyl Mercaptan	10 = 5
Carbon Disulfide	14 = 0	Sulfur Dioxide	300 = 0
Methanol	500 = 5	Toluene	32 = 0
Isopropanol	500 = 3	Ethanol	500 = 5

---

**NOTE:** The Detcon MOS Sensor Cell can be damaged to the point of non-functioning if the unit is left off power and in the presence normal air levels of moisture for periods exceeding 8 hours.

---



---

**NOTE:** Always protect the sensor cell with the Detcon Sealing Cap and a fresh desiccant

---

packet when the sensor is powered off, this will avoid permanent sensor cell damage and help preserve the span calibration.

## 2.4 Mounting Installation

The TP-700 sensor assembly is designed to be threaded into a 3/4" Female NPT fitting of a standard cast metal, Explosion-Proof Enclosure or Junction Box. There are two wrench flats on the upper section of the sensor that should be used to thread the sensor into the 3/4" NPT receiving connection. Thread the sensor up until tight (5 turns is typically expected) and until the display is pointed in the direction that sensor will normally be viewed and accessed.

**NOTE:** Do not use Teflon Tape or any other type of Pipe Thread material on the 3/4" threads unless the unit is mounted in a severe or harsh environment. Metal-on-metal contact must be maintained to provide a solid electrical ground path. If Teflon Tape is used the Sensor *must* be externally grounded using a ground strap.

The TP-700 should be vertically oriented so that the sensor points straight downward. The explosion-proof enclosure or junction box would then typically be mounted on a wall or pole. Detcon provides a standard selection of junction boxes available as sensor accessories (See Figure 4 below), but any appropriately rated enclosure with a downward facing 3/4" Female NPT connection will suffice.

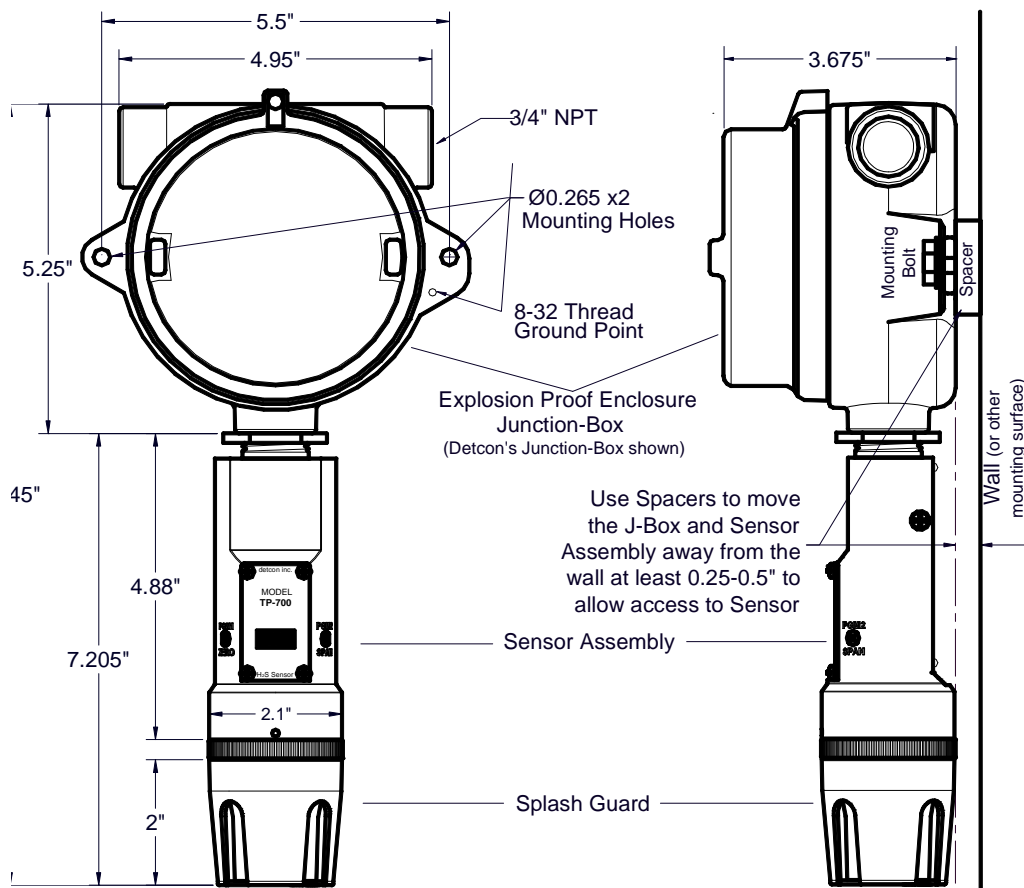

Figure 6 Outline and Mounting Dimensions

When mounting on a wall, it is recommended to use a 0.25"-0.5" spacer underneath the mounting ears of the Detcon standard J-Box to offset the sensor assembly from the wall and create open access around the sensor assembly. Spacing requirements for other junction boxes may vary.

When mounting on a pole, secure the Junction Box to a suitable mounting plate and attach the mounting plate to the pole using U-Bolts. (Pole-Mounting brackets for Detcon J-box accessories are available separately.)

## 2.5 Electrical Installation

The Sensor Assembly should be installed in accordance with local electrical codes. The sensor assemblies are CSA/NRTL approved (US and Canada) for Class I, Division 1, Groups B, C, & D area classifications, and are ATEX Approved for Class I, Zone 1, Group IIB+H<sub>2</sub> area classifications.

Proper electrical installation of the gas sensor is critical for conformance to Electrical Codes and to avoid damage due to water leakage. Refer to Figure 7 and Figure 8 for proper electrical installation.

**NOTE:** If a conduit run exits the secondary port, repeat the installation technique shown in Figure 7.

In Figure 7, the drain allows H<sub>2</sub>O condensation inside the conduit run to safely drain away from the sensor assembly. The electrical seal fitting is required to meet the National Electrical Code per NEC Article 500-3d (or Canadian Electrical Code Handbook Part 1 Section 18-154). Requirements for locations of electrical seals are covered under NEC Article 501-5. Electrical seals also act as a secondary seal to prevent water from entering the wiring terminal enclosure. However, they are not designed to provide an absolute watertight seal, especially when used in the vertical orientation.

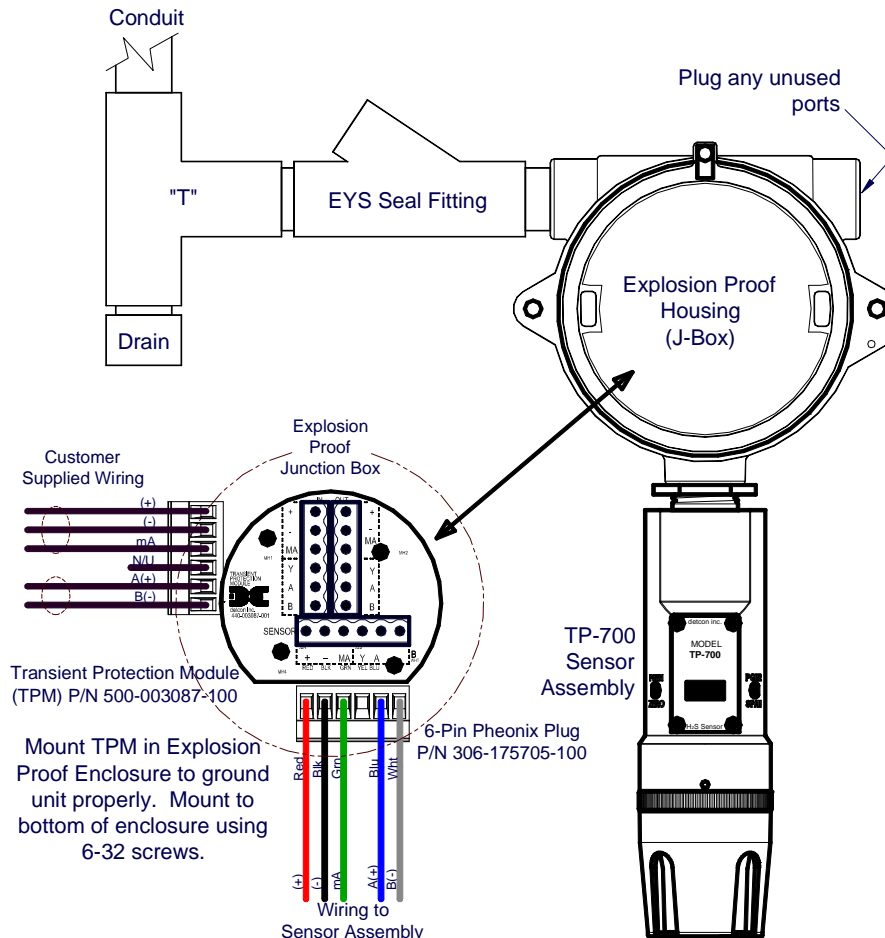

**Figure 7** Typical Installation

**NOTE:** A conduit seal is typically required to be located within 18" of the J-Box and Sensor Assembly. Crouse Hinds type EYS2, EYD2 or equivalent are suitable for this purpose.

**NOTE:** The Detcon Warranty does not cover water damage resulting from water leaking into the enclosure. However, since the electronics are 100% epoxy encapsulated, only the wire terminations could get wet. Moisture could cause abnormal operation and possibly corrosion to the terminal connections, but permanent damage to the sensor would not be expected.

**NOTE:** Any unused ports should be blocked with suitable 3/4" male NPT plugs. Detcon Supplies one 3/4" NPT male plug with their accessory J-box enclosures. If connections are other than 3/4" NPT, use an appropriate male plug of like construction material.

## 2.6 Field Wiring

Detcon Model TP-700 solid-state H<sub>2</sub>S sensor assemblies require three conductor connections between power supplies and host electronic controller's 4-20mA output, and 2 conductor connections for the Modbus™ RS-485 serial interface. Wiring designations are + (DC), - (DC), mA (sensor signal), and Modbus™ RS-485 A (+), and B (-). Maximum wire length between sensor and 24VDC source is shown in the Table below. Maximum wire size for termination in the Detcon J-Box accessory is 14 gauge.

**Table 2** Wire Gauge vs. Distance

AWG	Wire Dia.	Meters	Feet	Over-Current Protection
22	0.723mm	700	2080	3A
20	0.812mm	1120	3350	5A
18	1.024mm	1750	5250	7A
16	1.291mm	2800	8400	10A
14	1.628mm	4480	13,440	20A

**NOTE 1:** Wiring table is based on stranded tinned copper wire and is designed to serve as a reference only.

**NOTE 2:** Shielded cable is required for installations where cable trays or conduit runs include high voltage lines or other possible sources of induced interference. Separate conduit runs are highly recommended in these cases.

**NOTE 3:** The supply of power should be from an isolated source with over-current protection as stipulated in table.

### Terminal Connections



**CAUTION:** Do not apply System power to the sensor until all wiring is properly terminated. Refer to Section 2.7 Initial Start Up

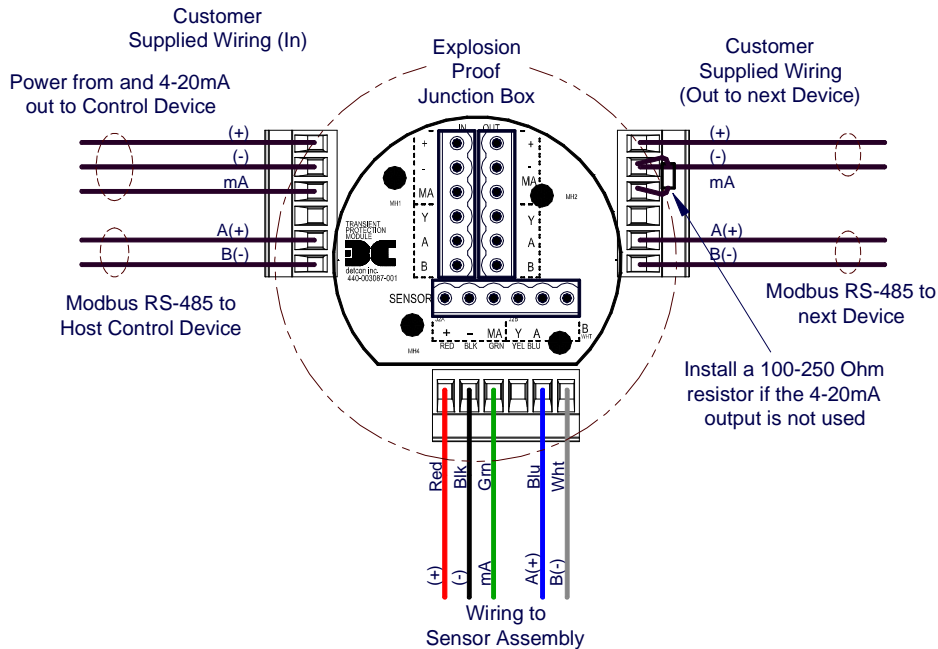

**Figure 8** Sensor Wire Connections

- a) Remove the junction box cover. Identify the terminal blocks for customer wire connections.
- b) Observing correct polarity, terminate the 3-conductor 4-20mA field wiring (+, -, and mA) to the sensor assembly wiring in accordance with the detail shown in Figure 8. If the 4-20mA output is not used, the green wire from the sensor must be connected to the (-) terminal on the Transient Protection Module.

**NOTE: If the 4-20mA output is not being used, the Green wire from the sensor *must* be connected to the Black wire at the (-) terminal on the Transient Protection Module to ensure RS-485 communication is not disrupted by a 4-20mA Fault.**

- c) If applicable, terminate the RS-485 serial wiring as shown in Figure 8. Use the second plug (Out) as termination point on the customer side to facilitate a continuous RS-485 serial loop.

The RS-485 (if applicable) requires 24 gauge, two conductor, shielded, twisted pair cable between sensor and host PC. General Cable Commodore part number ZO16P0022189 is recommended.

**NOTE: Install a 120Ω resistor across A & B terminals on the last sensor in the serial loop.**

- d) Trim all exposed wire leads if they are not permanently landed in the terminal block.
- e) Replace the junction box cover.

**NOTE: A 6-32 threaded exterior ground point is provided on the sensor housing for an external ground. If the Sensor Housing is not mechanically grounded, an external ground strap *must* be used to ensure that the sensor is electrically grounded.**

## 2.7 Initial Start Up

Upon completion of all mechanical mounting and termination of all field wiring, apply system power in the range of 11.5-30VDC (24VDC typical) and observe the following normal conditions:

- a) TP-700 display reads “0”, and no fault messages are flashing.
- b) A temporary upscale reading may occur as the sensor heats up. This upscale reading will decrease to “0” ppm within 1-2 minutes of power-up, assuming there is no gas in the area of the sensor.

---

**NOTE:** A desiccant cap with a desiccant packet is attached to the sensor cell housing to avoid damage during storage and shipping. This prevents water from contacting the sensor film, and as a result helps to retain the stability of the factory span calibration.

---

- c) Remove the desiccant cap about 10 minutes after applying power to the sensor and install the weatherproof splashguard accessory supplied with the sensor.

---

**IMPORTANT NOTE:** Do not remove the desiccant cap and cover until power is applied to the sensor. Store the desiccant caps with the desiccant packets in a sealed container (i.e. zip-lock Bag) for future use. It is mandatory to reinstall the desiccant cap and packet during any periods without power lasting more than 1 hour. An active desiccant packet is blue in color and turns pink when consumed. (re-order P/N 960-240010-000). Do not use the desiccant packet if it is pink in color, order new packets as required.

---

---

**NOTE:** The 4-20mA signal is held constant at 4mA for the first two minutes after power up.

---

### 2.7.1 Initial Operational Tests

After a warm up period of 1 hour, the sensor should be checked to verify sensitivity to H<sub>2</sub>S gas.

#### Material Requirements

- Detcon PN 613-120000-700 700 Series Splash Guard with integral Cal Port -OR-
- Detcon PN 943-000006-132 Threaded Calibration Adapter
- Detcon PN 942-010112-025 Span Gas; 25ppm H<sub>2</sub>S in balance Air at fixed flow rate between 200 - 500cc/min (10ppm for 0-20ppm range)
- Detcon PN 985-241100-321 In-Line Humidifying Tube

---

**NOTE:** Do not use H<sub>2</sub>S in Nitrogen background gas mixtures. This will cause significant reading inaccuracies.

---

- a) Connect the In-Line Humidifying Tube between the cal gas cylinder and the sensor. The humidifying tube will introduce the ambient relative humidity into the Cal Gas as it passes through the tube.
- b) Attach the calibration adapter to the threaded sensor housing. Apply the test gas at a controlled flow rate of 200 - 500cc/min (200cc/min is the recommended flow). Allow 1-2 minutes for the reading to stabilize. Observe that during the 1-2 minutes the ITM display increases to a level near that of the applied calibration gas value.
- c) Remove test gas and observe that the ITM display decreases to “0”.

Initial operational tests are complete. Detcon H<sub>2</sub>S gas sensors are factory calibrated prior to shipment, and should not require significant adjustment on start up. However, it is recommended that a complete calibration test and adjustment be performed 16 to 24 hours after power-up. Refer to span calibration instructions in Section 3.4.

## 3. Operation

### 3.1 Programming Magnet Operating Instructions

The Operator Interface of the Model 700 Series gas sensors is accomplished via two internal magnetic switches located to either side of the LED display (see Figure 10). The two switches, labeled “PGM1” and “PGM2”, allow for complete calibration and configuration, thereby eliminating the need for area de-classification or the use of hot permits.



**Figure 9** Magnetic Programming Tool

The magnetic programming tool (Figure 9) is used to operate the magnetic switches. Switch action is defined as momentary contact, 3-second hold, and 10-second hold. (Hold times are defined as the time from the point when the arrow prompt “▶” appears.) For momentary contact use, the programming magnet is briefly held over a switch location. For 3-second hold, the programming magnet is held in place over the switch location for three seconds. For 10-second hold, the programming magnet is held in place over the switch location for 10 seconds. The 3 and 10 second holds are generally used to enter calibration/program menus and save new data. The momentary contact is generally used to move between menu items and to modify set-point values. Arrows (“▶” and “◀”) are used on the LED display to indicate when the magnetic switches are activated. The location of “PGM1” and “PGM2” are shown in Figure 10.

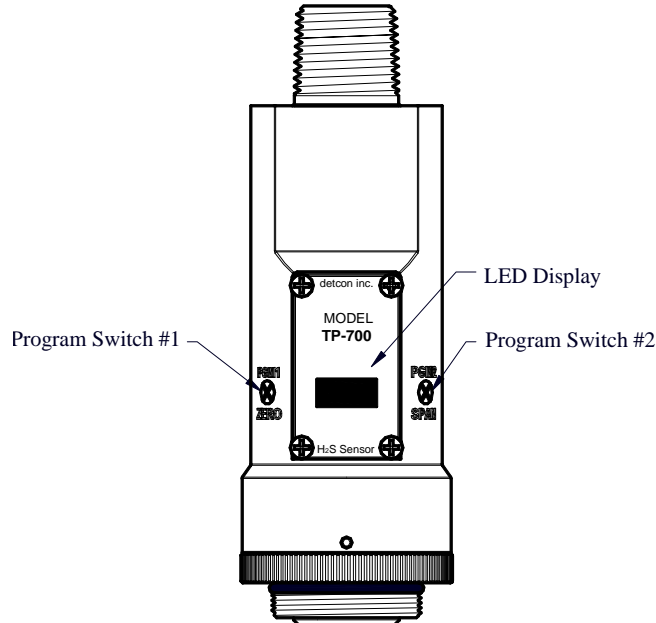

**Figure 10** Magnetic Programming Switches

---

**NOTE:** While in the Program Mode, if there is no magnetic switch interaction after 4 consecutive menu scrolls, the sensor will automatically revert to normal operating condition. While changing values inside menu items, **if there is no magnet activity after 3-4 seconds the sensor will revert to the menu scroll.** (Exception to this is with “Signal Output Check” mode.)

---



## 3.2 Operator Interface

The operating interface is menu-driven via the two magnetic program switches located under the target marks of the sensor housing. The two switches are referred to as “PGM1” and “PGM2”. The menu list consists of three major items that include sub-menus as indicated below. (Refer to the complete Software Flow Chart.)

### Normal Operation

- Current Reading and Fault Status

### Calibration Mode

- AutoSpan

### Program Mode

- View Sensor Status
  - Sensor Model Type
  - Current Software Version
  - Range of Detection
  - Serial ID address
  - AutoSpan Level
  - Days Since Last AutoSpan
  - Remaining Sensor Life
  - Sensor Heater Power
  - Sensor Heater Voltage
  - Raw Sensor Resistance
  - mA Output
  - Input Voltage Supply
  - Sensor Temperature
- Set AutoSpan Level
- Set Range
- Set Serial ID
- Set Heater Power
- Signal Output Check
- Restore Default Settings

## Software Flowchart

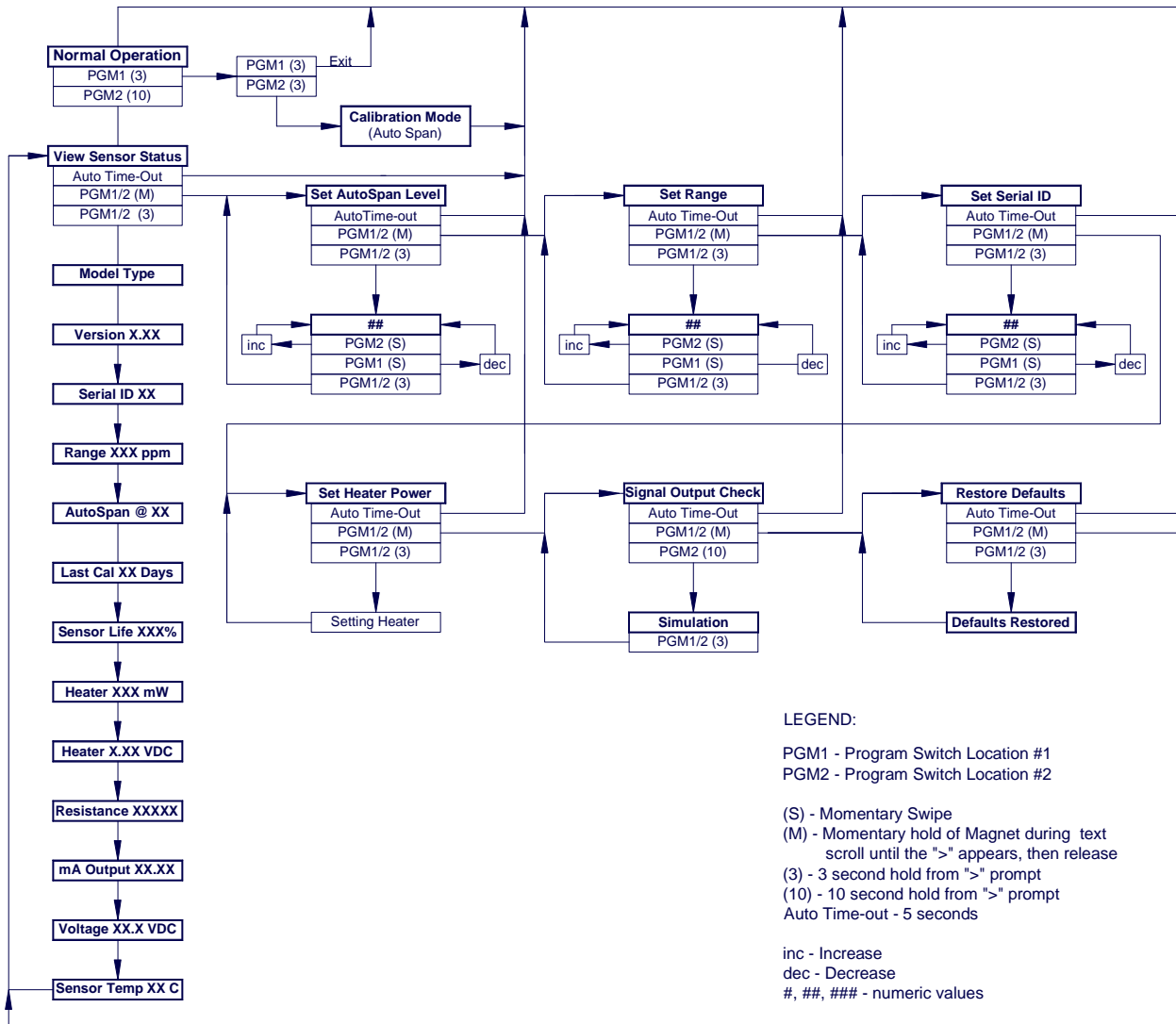

**Figure 11 TP-700 Software Flowchart**

### 3.3 Normal Operation

In normal operation, the ITM Display continuously shows the current sensor reading, which will normally appear as “ 0 ”. Once every minute, the LED display will flash the sensor’s units of measure and the gas type (i.e. ppm H<sub>2</sub>S). If the sensor is actively experiencing any diagnostic faults, a “Fault Detected” message will scroll across the display on the ITM display once every minute instead of the units of measure and the gas type. At any time, while the sensor is in “Fault Detected” mode, PGM1 or PGM2 can be swiped to prompt the sensor to display a list of the active faults.

In normal operation, the 4-20mA current output linearity corresponds with the full-scale range. The RS-485 Modbus™ serial output provides the current gas reading and complete fault status on a continuous basis when polled by the master device.

### 3.4 Calibration Mode (AutoSpan)

Calibration Mode allows for sensor span calibration. Span calibration should be performed on a routine basis (quarterly minimum) to ensure reliable performance. If a sensor has been exposed to any de-sensitizing gases or to very high over-range H<sub>2</sub>S levels, then a re-calibration should be considered. Unless otherwise specified, span adjustment is recommended at 25ppm for the 0-100 and 0-50ppm ranges (and 10ppm for 0-20ppm range). This function is called “AUTO SPAN”.

#### Material Requirements:

- Detcon PN 327-000000-000 MicroSafe™ Programming Magnet
- Detcon PN 613-120000-700 700 Series Splash Guard with integral Cal Port and Calibration Wind Guard (P/N 943-000000-000) -OR-
- Detcon PN 943-000006-132 Threaded Calibration Adapter
- Detcon PN 985-241100-321 In-Line Humidifying Tube
- Detcon PN 942-010112-025 H<sub>2</sub>S Span Gas (recommended) or other suitable span gas source containing H<sub>2</sub>S gas in air balance. A fixed flow rate of 200-500cc/min is recommended.

#### Alternate Span Calibration Methods:

The TP-700 Sensor may also be calibrated with the H<sub>2</sub>S glass ampoule technique. Detcon supplies a cover for use with the industry standard ampoule breaking cup (available from General Monitors) that has thread adapter to connect to the TP-700. The adapter cover is Detcon P/N 943-000GMI-CAP.

Remove the Detcon Splashguard and connect the adapter cover firmly in place. Attach the ampoule breaking cup firmly to the cover with ampoule installed and follow the balance of the instructions for breaking ampoule and executing AutoSpan.

The TP-700 sensor may also be calibrated using a certified H<sub>2</sub>S gas generator product set for the correct H<sub>2</sub>S gas level and flow rate.

---

**NOTE 1:** Before performing AutoSpan Calibration, verify that the AutoSpan level matches the span calibration gas concentration as described in Section 3.5.3 Set AutoSpan Level.

---

---

**NOTE 2:** The span gas source must have a normal background concentration of 20.9% O<sub>2</sub> (H<sub>2</sub>S balanced with Air). Pure Nitrogen background mixtures are not acceptable! Significant span calibration inaccuracies will result.

---

---

**NOTE 3:** An H<sub>2</sub>S gas concentration of 25ppm is strongly recommended for 0-50 and 0-100ppm ranges (10ppm span gas for 0-20ppm range). This should be supplied at a controlled flow rate of 200 to 500cc/min, with 200cc/min being the recommended flow rate. Other concentrations can be used if as they fall within allowable levels.

---

---

**NOTE 4:** Span gas bottles contain 0% humidity and this ultra-low humidity condition will cause inaccurate readings when used to calibrate a sensor. To prevent this error, Detcon prescribes the use of a 24” flexible In-Line Humidifying Tube, which adds the relative humidity to the span gas. The humidifying tube is not necessary when using a gas generating calibration device that consists of pumped ambient air and an H<sub>2</sub>S generating source.

---

---

**NOTE 5:** The Calibration Wind Guard must be used when the Splashguard Adapter with integral Cal Port is used. Failure to use the Calibration Wind Guard may result in an inaccurate

---

---

 AutoSpan calibration.
 

---



**CAUTION:** Verification that the calibration gas level setting matches the calibration span gas concentration is required before executing “AutoSpan” calibration. These two numbers must be equal.

AutoSpan consists of entering Calibration Mode and following the menu-displayed instructions. The display will ask for the application of span gas in a specific concentration. The applied gas concentration must be equal to the calibration gas level setting. The factory default setting and recommendation for span gas concentration is 10ppm for the 0-20ppm range and 25ppm for the 0-50ppm and 0-100ppm ranges. If a span gas containing the recommended concentration is not available, other concentrations may be used as long as they fall between 10% and 50% of selected full-scale range. However, any alternate span gas concentration value must be programmed via the “Set AutoSpan Level” menu before proceeding with AutoSpan calibration. Follow the instructions “a” through “e” below for AutoSpan calibration.

- a) Verify that the AutoSpan Level is equal to the Calibration Span Gas Concentration. (Refer to View Sensor Status in Section 3.5.2.) If the AutoSpan Level is not equal to the Calibration span gas concentration, adjust the AutoSpan Level as instructed in Section 3.5.3 Set AutoSpan Level.
- b) From Normal Operation, enter Calibration Mode by holding the programming magnet over PGM1 for 3 seconds. Note, the “▶” prompt will show that the magnetic switch is activated during the 3 second hold period. The display will then scroll “PGM1=Exit PGM2=Span”. Hold the programming magnet over PGM2 for 3 seconds to execute AutoSpan (or allow to timeout in 5 seconds if AutoSpan is not intended). The ITM will then scroll “Apply XX ppm Gas”.

---

**NOTE:** Upon entering Calibration Mode, the 4-20mA signal drops to 2mA and is held at this level until the program returns to normal operation. Modbus™ Status Register bit 14 is also set to signify when the sensor is in-calibration mode.

---

- c) Apply the span calibration test gas via the In-Line Humidifying Tube at a flow rate of 200-500cc/min (200cc/min is the recommended flow rate). Optionally, the gas ampoule or gas generator H<sub>2</sub>S calibration source may be used. As the sensor signal begins to increase the display will switch to reporting “XX” reading methods as the ITM shows the sensor’s “as found” response to the span gas presented. If it fails to meet the minimum in-range signal change criteria within 2½ minutes, the display will report “Range Fault” twice and the ITM will return to normal operation, aborting the AutoSpan sequence. The ITM will continue to report a “Range Fault” and will not clear the fault until a successful AutoSpan is completed.

Assuming acceptable sensor signal change, after 3 minutes the reading will auto-adjust to the programmed AutoSpan level. During the next 30 seconds, the AutoSpan sequence checks the sensor for acceptable reading stability. If the sensor fails the stability check, the reading is re-adjusted back to the AutoSpan level and the cycle repeats until the stability check is passed. Up to three additional 30-second stability check periods are allowed before the sensor reports a “Stability Fault” twice and the ITM will return to normal operation, aborting the AutoSpan sequence. The ITM will continue to report a “Stability Fault” and will not clear the fault until a successful AutoSpan is completed.

If the sensor passes the stability check, the ITM reports a series of messages:

“AutoSpan Complete”  
 “Sensor Life XXX%”  
 “Remove Span Gas”

- d) Remove the span gas and calibration adapter, or the optional gas ampoule or gas generator calibration technique components when AutoSpan cycle is complete. The ITM will report a live reading as it clears toward “0”. When the reading clears below 5ppm, the ITM will display “Span Complete” and will revert

to normal operation. If the sensor fails to clear to less than 5ppm within 5 minutes, a “Clearing Fault” will be reported twice and the ITM will return to normal operation, aborting the AutoSpan sequence. The ITM will continue to report a “Clearing Fault” and will not clear the fault until a successful AutoSpan is completed.

- e) AutoSpan calibration is complete.

---

**NOTE 1:** If the sensor fails the minimum signal change criteria, a “**Range Fault**” will be declared and a “Fault Detected” message will be displayed alternately with the sensor’s current reading. The 4-20mA output will be taken to 0mA and the “Range Fault” fault bit will be set on the Modbus™ output.

---

---

**NOTE 2:** If the sensor fails the stability criteria, a “**Stability Fault**” will be declared and a “Fault Detected” message will be displayed alternately with the sensor’s current reading. The 4-20mA output will be taken to 0mA and the “Stability Fault” fault bit will be set on the Modbus™ output.

---

---

**NOTE 3:** If the sensor fails the clearing time criteria, a “**Clearing Fault**” will be declared and a “Fault Detected” message will be displayed alternately with the sensor’s current reading. The 4-20mA output will be taken to 0mA and the “Clearing Fault” fault bit will be set on the Modbus™ output.

---

---

**NOTE 4:** The most common cause of “**Range Fault**” and “**Stability Fault**” is the improper storage of the unit / sensor cell. When the sensor power is removed for any period of time, the sensor cell should be protected with a Desiccant Pack (P/N 960-240010-000) and covered by the Dust Cap (P/N 600-003232-000)

---



## 3.5 Program Mode

Program Mode provides a “View Sensor Status” menu to check operational and configuration parameters. Program Mode provides for adjustment of the AutoSpan Level, Sensor Range, Heater Power, and Serial ID. Additionally, Program Mode includes the diagnostic function “Signal Output Check” and “Restore Factory Defaults”.

The Program Mode menu items appear in the order presented below:

- View Sensor Status
- Set AutoSpan Level
- Set Range
- Set Serial ID
- Set Heater Power
- Signal Output Check
- Restore Default Settings

### 3.5.1 Navigating Program Mode

From Normal Operation, enter Program Mode by holding the magnet over PGM2 for 4 seconds (until the display starts to scroll “View Sensor Status”). Note, the “” prompt will show that the magnetic switch is activated during the 4 second hold period. The ITM will enter Program Mode and the display will display the first menu item “View Sensor Status”. To advance to the next menu item, hold the magnet over PGM1 or PGM2 while the current menu item’s text is scrolling. At the conclusion of the text scroll the arrow prompt (“” for PGM2 or “” for PGM1) will appear, immediately remove the magnet. The ITM will advance to the

next menu item. Repeat this process until the desired menu item is displayed. Note, PGM1 moves the menu items from right to left and PGM2 moves the menu items from left to right.

To enter a menu item, hold the magnet over PGM1 or PGM2 while the menu item is scrolling. At the conclusion of the text scroll the “▶” prompt (“▶” for PGM2 or “◀” for PGM1) will appear, continue to hold the magnet over PGM1 or PGM2 for an additional 3-4 seconds to enter the selected menu item. If there is no magnet activity while the menu item text is scrolling (typically 4 repeated text scrolls), the ITM will automatically revert to Normal Operation.

### 3.5.2 View Sensor Status

**View Sensor Status** displays all current configuration and operational parameters including: sensor type, software version number, detection range, AutoSpan level, days since last AutoSpan, estimated remaining sensor life, heater power, heater voltage, raw resistance, mA output, input voltage and sensor ambient temperature.

From the **View Sensor Status** text scroll, hold the magnet over PGM1 or PGM2 until the “▶” prompt appears and continue to hold the magnet in place for an additional 3-4 seconds (until the display starts to scroll “Status Is”). The display will scroll the complete list of sensor status parameters sequentially:

#### **Sensor Model Type**

The menu item appears as: “700 TP”

#### **Current Software Version**

The menu item appears as: “V X.XXZ”

#### **Range of Detection.**

The menu item appears as: “Range XXXppm”

#### **Serial ID address.**

The menu item appears as: “Serial ID XX”

#### **AutoSpan Level.**

The menu item appears as: “Auto Span Level XXppm”

#### **Days Since Last AutoSpan.**

The menu items appears as: “Last Cal XX days”

#### **Remaining Sensor Life.**

The menu item appears as: “Sensor Life 100%”

#### **Sensor Heater Power**

The menu item appears as: “Heater XXXmW”

#### **Sensor Heater Voltage**

The menu item appears as: “Heater X.XXVDC”

### Raw Sensor Resistance

The menu item appears as: “Resistance XXXXX”

### mA Output

The menu item appears as: “mA Output XX.XX mA”

### Input Voltage Supply

The menu item appears as: “Voltage XX.X VDC”

### Operating Temperature

The menu item appears as: “Temp XX C”

When the status list sequence is complete, the ITM will revert to the “View Sensor Status” text scroll. The user can either: 1) review list again by executing another 3-4 second hold, 2) move to another menu item by executing a momentary hold over PGM1 or PGM2, or 3) return to Normal Operation via automatic timeout of about 15 seconds (the display will scroll “View Sensor Status” 4 times and then return to Normal Operation).

### 3.5.3 Set AutoSpan Level

**Set AutoSpan Level** is used to set the span gas concentration level that is being used to calibrate the sensor. This level is adjustable from 10% to 50% of selected full-scale range. The current setting can be viewed in View Program Status.

The menu item appears as: “**Set AutoSpan Level**”.

From the **Set AutoSpan Level** text scroll, hold the magnet over PGM1 or PGM2 until the “▶” prompt appears and continue to hold the magnet in place for an additional 3-4 seconds (until the display starts to scroll “Set Level”). The display will switch to “ XX “ (where XX is the current gas level). Swipe the magnet momentarily over PGM2 to increase or PGM1 to decrease the AutoSpan Level until the correct level is displayed. When the correct level is achieved, hold the magnet over PGM1 or PGM2 for 3-4 seconds to accept the new value. The display will scroll “Level Saved”, and revert to “Set AutoSpan Level” text scroll.

Move to another menu item by executing a momentary hold, or return to Normal Operation via automatic timeout of about 15 seconds (the display will scroll “Set AutoSpan Level” 4 times and then return to Normal Operation).

### 3.5.4 Set Range

**Set Range** is used to change full-scale ranges. This is selectable between 0-20, 0-50, 0-100ppm, and 0-200ppm. The current range can be viewed in View Sensor Status using instruction given in Section 3.5.2 View Sensor Status.

The menu item appears as: “**Set Range**”.

From the “**Set Range**” text scroll, hold the programming magnet over PGM1 or PGM2 until the “▶” prompt appears and continue to hold the magnet in place for an additional 3-4 seconds (until the display starts to scroll “Set Range”). The display will then switch to “XXX“ (where XXX is the current Range). Swipe the magnet momentarily over PGM2 to increase or PGM1 to decrease the range Level until the desired range is displayed.

Hold the magnet over PGM1 or PGM2 for 3 seconds to accept the new value. The display will scroll “Range Saved”, and revert to “Set Range” text scroll.

Move to another menu item by executing a momentary hold, or, return to Normal Operation via automatic timeout of about 15 seconds (the display will scroll “Set Range” 7 times and then return to Normal Operation).

---

**NOTE:** When switching between ranges, it may be necessary to readjust the AutoSpan Level.

---

### 3.5.5 Set Serial ID

Detcon Model TP-700 sensors can be polled serially via RS-485 Modbus™ RTU. Refer to Section 4.0 for details on using the Modbus™ output feature.

**Set Serial ID** is used to set the Modbus™ serial ID address. It is adjustable from 01 to 256 in hexadecimal format (01-FF hex). The current serial ID can be viewed in View Sensor Status using the instruction given in Section 3.5.2 View Sensor Status.

The menu item appears as: “**Set Serial ID**”.

From the “**Set Serial ID**” text scroll, hold the programming magnet over PGM1 or PGM2 until the “◆” prompt appears and continue to hold the magnet in place for an additional 3-4 seconds (until the display starts to scroll “Set ID”). The display will then switch to “XX” (where XX is the current ID address). Swipe the magnet momentarily over PGM2 to increase or PGM1 to decrease the hexadecimal number until the desired ID is displayed. Hold the magnet over PGM1 or PGM2 for 3-4 seconds to accept the new value. The display will scroll “ID Saved”, and revert to “Set Serial ID” text scroll.

Move to another menu item by executing a momentary hold, or, return to Normal Operation via automatic timeout of about 15 seconds (the display will scroll “Set Serial ID” 5 times and then return to Normal Operation).

### 3.5.6 Set Heater Power

Set Heater Power is used to set the each H<sub>2</sub>S sensor to the optimum operating temperature. This function is performed during factory calibration of each TP-700 sensor assembly, and is not necessary during installation. However, it is necessary to perform in the field if the plug-in H<sub>2</sub>S sensor is replaced or if the Restore Factory Defaults function has been executed.

The menu item appears as: “**Set Heater Power**”.

---

**NOTE:** “Set Heater Power” is only necessary after new plug-in H<sub>2</sub>S sensor installation or after use of the “Restore Factory Defaults” function. A full 3-4 second magnet hold on PGM1 or PGM 2 is required to execute this function.

---

From the “Set Heater Power” text scroll, hold the programming magnet over PGM1 or PGM2 until the “◆” prompt appears and continue to hold the magnet in place for an additional 3-4 seconds (until the display starts to scroll “Setting Heater”). After scrolling “Setting Heater”, the ITM will adjust the Heater power. The sequence should require about 2-minutes. When the cycle is complete, the ITM will revert to the “Set Heater Power” text scroll.

---

**NOTE:** If the ITM cannot adjust the heater power within 3 minutes an error message, “Can’t set, Reverting to Default”, will be scrolled. Refer to section 6 Troubleshooting Guide.

---



Move to another menu item by executing a momentary hold, or, return to Normal Operation via automatic timeout of about 15 seconds (the display will scroll “Set Heater Power” 4 times and then return to Normal Operation).

The current values for heater power and heater voltage can be observed in the “View Sensor Status” menu. The target heater power setting at 25C operating temperature is 235 +/- 5mW. At the operating temperature extremes the observed heater power settings will vary according to the data below:

50°C	normal heater power range is 215 +/- 5mW
0°C	normal heater power range is 260 +/- 5mW
-20°C	normal heater power range is 275 +/- 5mW
-40°C	normal heater power range is 295 +/- 5mW

### 3.5.7 Signal Output Check

**Signal Output Check** provides a simulated 4-20mA output and RS-485 Modbus™ output. This simulation allows the user to conveniently perform a functional system check of their entire safety system. This signal output simulation also aids the user in performing troubleshooting of signal wiring problems.

The menu item appears as: “**Signal Output Check**”.

From the “Signal Output Check” text scroll, hold the magnet over PGM1 or PGM2 until the “◆” prompt appears and then hold continuously for an additional 10 seconds. Once initiated, the display will scroll “Simulation Active” until the function is stopped. During simulation mode, the 4-20mA value will be increased from 4.0mA to 20.0mA (in 1% of range increments at about a 1 second update rate) and then decreased from 20.0mA to 4.0mA. The same simulation sequence is applied to the Modbus™ output gas reading.

---

**NOTE:** Signal Output Check stays active indefinitely until the user stops the function. There is no automatic timeout for this feature.

---

To end simulation mode, hold magnet over PGM1 or PGM2 for 3 seconds. The display will either move to the prior menu item or move to the next menu item respectively.

Move to another menu item by executing a momentary hold, or, return to Normal Operation via automatic timeout of about 15 seconds.

### 3.5.8 Restore Factory Defaults

**Restore Factory Defaults** is used to clear current user configuration and calibration data from memory and revert to factory default values. This may be required if the settings have been configured improperly and a known reference point needs to be re-established to correct the problem.

This menu item appears as: “**Restore Defaults**”.

---

**NOTE:** “Restoring Factory Defaults” should only be used when absolutely necessary. All previously existing configurational inputs will have to be re-entered if this function is executed. A full 10-second magnet hold on PGM 2 is required to execute this function.

---

From the “Restore Defaults” text scroll, hold the programming magnet over PGM2 until the “◆” prompt appears and continue to hold 10 seconds. The display will scroll “Restoring Defaults”, and then will revert to the “Restore Defaults” text scroll.

Move to another menu item by executing a momentary hold, or, return to Normal Operation via automatic timeout of about 15 seconds (the display will scroll “Restore Defaults” 4 times and then return to Normal Operation).

Following the execution of “**Restore Defaults**”, the TP-700 will revert to its factory default settings. The default settings are:

- Serial ID = 01. The Serial ID must be set appropriately by the operator (3.5.5).

**NOTE:** The following must be performed in order before the sensor can be placed in operation.

- Range = 100ppm. Range must be set appropriately by the operator (3.5.4).
- AutoSpan Level = 25ppm. AutoSpan level must be set appropriately by the operator (3.5.3).
- Heater Power: Heater Power settings are lost and “Set Heater Power” (3.5.6) must be performed before “AutoSpan”.
- AutoSpan: AutoSpan Settings are lost and a successful “AutoSpan” must be performed before placing the Sensor into operation (3.4).

## 3.6 Program Features

Detcon TP-700 H<sub>2</sub>S gas sensors incorporate a comprehensive set of diagnostic features to achieve Fail-Safe Operation. These Operational features and Failsafe Diagnostic features are detailed below.

### 3.6.1 Operational Features

#### Over-Range

When gas greater than the full-scale range is detected, the ITM display will continuously flash the full-scale reading (20, 50, 100ppm, 200ppm). This designates an over-range condition. The 4-20mA signal will report a 22mA output during this time.

#### In-Calibration Status

When the sensor is engaged in AutoSpan calibration, the 4-20mA output signal is taken to 2.0mA and the in-calibration Modbus™ Status Register bit 14 is set. This alerts the user that the ITM is not in an active measurement mode. This feature also allows the user to log the AutoSpan events via their master control system.

#### Sensor Life

Sensor Life is calculated after each AutoSpan calibration and is reported as an indicator of remaining service life. It is reported in the “View Sensor Status” menu and as a RS-485 Modbus™ register bit. Sensor Life is reported on a scale of 0-100%. When Sensor Life falls below 25%, the sensor cell should be replaced within a reasonable maintenance schedule.

#### Last AutoSpan Date

This reports the number of days that have elapsed since the last successful AutoSpan. This is reported in the View Sensor Status menu. After 180 days, an AutoSpan Fault will be declared.

### 3.6.2 Fault Diagnostic/Failsafe Features

## Fail-Safe/Fault Supervision

Model TP-700 MicroSafe™ sensors are designed for Fail-Safe operation. If any of the diagnostic faults listed below are active, the ITM Display will scroll the message “Fault Detected” every 30 seconds during normal operation. At any time during “Fault Detected” mode, holding the programming magnet over PGM1 or PGM2 for 1 second will display the active fault(s). All active faults are reported sequentially.

Most fault conditions result in failed operation of the sensor. In these cases the 4-20mA signal is dropped to the universal fault level of 0mA. These include the AutoSpan Calibration faults, Heater Fault, Sensor Fault, Processor Fault, Memory Fault, Loop Fault, and Input Voltage Fault. (The 0mA fault level is not employed for a Temperature Fault, or during Calibration.) For every diagnostic fault condition the associated RS-485 Modbus™ fault register will be flagged to alert the user digitally.

---

**NOTE:** Refer to the Troubleshooting Guide, Section 6, for guidance on fault conditions.

---

### Range Fault – AutoSpan

If the sensor fails the minimum signal change criteria during AutoSpan sequence (Section 3.4), the “Range Fault” will be declared. A “Range Fault” will cause a “Fault Detected” message to scroll once a minute on the ITM display and drop the 4-20mA output to 0mA. The Modbus™ fault register bit for Range Fault will be set and will not clear until the fault condition has been cleared. The sensor should be considered “Out-of-Service” until a successful AutoSpan calibration is performed.

### Stability Fault - AutoSpan

If the sensor fails the signal stability criteria during AutoSpan sequence (Section 3.4), the “Stability Fault” will be declared. A “Stability Fault” will cause a “Fault Detected” message to scroll once a minute on the ITM display and drop the mA output to 0mA. The Modbus™ fault register bit for Stability Fault will be set and will not clear until the fault condition has been cleared. The sensor should be considered as “Out-of-Service” until a successful AutoSpan calibration is performed.

### Clearing Fault - AutoSpan

If the sensor fails the signal stability criteria during AutoSpan sequence (Section 3.4), the “Clearing Fault” will be declared. A “Clearing Fault” will cause a “Fault Detected” message to scroll once a minute on the ITM display and drop the mA output to 0mA. The Modbus™ fault register bit for Clearing Fault will be set and will not clear until the fault condition has been cleared. The sensor should be considered as “Out-of-Service” until a successful AutoSpan calibration is performed.

### Open Heater Fault

If the sensor heater should fail and become electrically open, a “Heater Fault” will be declared. A “Heater Fault” will cause a “Fault Detected” message to scroll once a minute on the ITM display. The Modbus™ fault register bit for Heater Fault will be set and will not clear until the fault condition has been cleared. If a Heater Fault occurs, the 4-20mA signal will be set at 0mA until the fault condition is resolved.

### Open Sensor Fault

If the sensor film should fail and become electrically open, a “Sensor Fault” is declared. A “Sensor Fault” will cause a “Fault Detected” message to scroll once a minute on the ITM display. The Modbus™ fault register bit for Sensor Fault will be set and will not clear until the fault condition has been cleared. If a Sensor Fault occurs, the 4-20mA signal will be set at 0mA until the fault condition is resolved.

## Processor Fault

If the detector has any unrecoverable run-time errors, a “Processor Fault” is declared. A “Processor Fault” will cause a “Fault Detected” message to scroll once a minute on the ITM display. The Modbus™ fault register bit for Processor Fault will be set and will not clear until the fault condition has been cleared. If a Processor Fault occurs, the 4-20mA signal will be set at 0mA until the fault condition is resolved.

## Memory Fault

If the detector has a failure in saving new data to memory, a “Memory Fault” is declared. A “Memory Fault” will cause the “Fault Detected” message to scroll once a minute on the ITM display. The Modbus™ fault register bit for Memory Fault will be set and will not clear until the fault condition has been cleared. If a Memory Fault occurs, the 4-20mA signal will be set at 0mA until the fault condition is resolved.

## 4-20mA Loop Fault

If the sensor detects a condition where the 4-20mA output loop is not functional (high loop resistance or failed circuit function) a “4-20mA Fault” is declared. A “4-20mA Fault” will cause the “Fault Detected” message to scroll once a minute on the ITM display. The Modbus™ fault register bit for Loop Fault will be set and will not clear until the fault condition has been cleared. If a Loop Fault occurs, the 4-20mA signal will be set at 0mA until the fault condition is resolved. If the 4-20mA current loop is still out of tolerance, contact Detcon at [Service@detcon.com](mailto:Service@detcon.com), or contact Detcon customer service.

---

**NOTE: If the 4-20mA output is not being used, the Green wire from the sensor *must* be connected to the Black wire at the (-) terminal on the Transient Protection Module to ensure RS-485 communication is not disrupted by a 4-20mA Fault.**

---

## Input Voltage Fault

If the detector is currently receiving an input voltage that is outside of the 11.5-28VDC range, an “Input Voltage Fault” is declared. An “Input Voltage Fault” will cause the “Fault Detected” message to scroll once a minute on the ITM display. The fault register bit for Input Voltage Fault will be set and will not clear until the fault condition has been cleared. If an Input Voltage Fault occurs, the 4-20mA signal will be set at 0mA until the fault condition is resolved.

## Temperature Fault

If the detector is currently reporting an ambient temperature that is outside of the  $-40^{\circ}\text{C}$  to  $+75^{\circ}\text{C}$  range, a “Temperature Fault” is declared. A “Temperature Fault” will cause the “Fault Detected” message to scroll once a minute on the ITM display. The Modbus™ fault register bit for Temperature Fault will be set and will not clear until the fault condition has been cleared. If a Temperature Fault occurs, the 4-20mA signal remains operational.

## AutoSpan Fault

If 180 days has elapsed since the last successful AutoSpan, an AutoSpan Fault will be generated. An “AutoSpan Fault” will cause the “Fault Detected” message to scroll once a minute on the ITM display. The Modbus™ fault register bit for AutoSpan Reminder Fault will be set and will not clear until the fault condition has been cleared. If an AutoSpan Reminder Fault occurs, the 4-20mA signal remains operational.

## 4. RS-485 Modbus™ Protocol

Model DM-700 sensors feature Modbus™ compatible communications protocol and are addressable via the program mode. Other protocols are available. Contact the Detcon factory for specific protocol requirements. Communication is two wire, half duplex 485, 9600 baud, 8 data bits, 1 stop bit, no parity, with the sensor set up as a slave device. A master controller up to 4000 feet away can theoretically poll up to 256 different sensors. This number may not be realistic in harsh environments where noise and/or wiring conditions would make it impractical to place so many devices on the same pair of wires. If a multi-point system is being utilized, each sensor should be set for a different address. Typical address settings are: 01, 02, 03, 04, 05, 06, 07, 08, 09, 0A, 0B, 0C, 0D, 0E, 0F, 10, 11...etc.

Sensor RS-485 ID numbers are factory default to 01. These can be changed in the field via the Operator Interface described in Section 3.5.5 Set Serial ID.

The following section explains the details of the Modbus™ protocol that the DM-700 sensor supports.

Code 03 - Read Holding Registers is the only code supported by the transmitter. Each transmitter contains 6 holding registers which reflect its current status.

**Table 3** Modbus™ Registers

FC	REG	Content Description	R/W	Content Definition		
				Value	Meaning	Range
03	40000	Device Type	R	8	700 Sensor	
03 06	40001 40001	Read Detectable Range <sup>1,2</sup> Write Detectable Range	R/W	100 10000	For 0-100 For 0-10000 <sup>2</sup>	DM – 0 to 10000 FP – Read only TP – 20, 50, 100, 200 IR – 0 to 10000 PI – 0 to 10000
03	40002	Read Concentration <sup>3,2</sup>	R	1000	Bound by range. If > range, this value is in fault.	
03 06	40003 40003	Read AutoSpan Level <sup>4,2</sup> Write AutoSpan Level	R/W	50	Span gas at 50	DM – 1% to 95% of Range (40001) FP – 5% to 95% of Range (40001) TP – 2% to 50% of Range (40001) IR – 5% to 95% of Range (40001) PI – 1% to 95% of Range (40001)
03	40004	Read Sensor Life	R	85	For 85% sensor life	
03	40005	Read Fault Status Bits <sup>5</sup>	R	0x0001 0x0002 0x0004 0x0008 0x0010 0x0020 0x0040 0x0080 0x0100 0x0200 0x0400 0x0800 0x1000 0x2000 0x4000 0x8000	Global Fault Auto Span Fault Temperature Fault 4-20mA Fault Input Voltage Fault Memory Fault Processor Fault Clearing Fault Stability Fault Range Fault Sensor Fault Zero Fault Sensor Fault 2 <reserved> In Calibration Communication Error	
03	40006	Read Model #	R	1, 2, 3, 4, 5	DM, FP, IR, TP, PID respectively	
03	40007	Read Days Since Cal	R	29	29days	
03	40008	4-20 Current Output mA x100	R	400	4.00mA	<b>Range</b>
03	40009	Read Input Voltage V x100	R	2400	24.00V	
03	40010	Read Temperature	R	28	28 °C	
03/ 06	40011	Special #1	R/W		Function dependent on value of 40006 (See Special Register Table 4)	

FC	REG	Content Description	R/W	Content Definition		
				Value	Meaning	Range
03/06	40012	Special #2	R/W		Function dependent on value of 40006 (See Special Register Table 4)	
03	40013	Special #3	R		Function dependent on value of 40006 (See Special Register Table 4)	
03/06	40014	Special #4	R/W		Function defendant on value of 40006 (See Special Register Table 4)	
03	40015	Calibration Status	R	0x0000 0x0001 0x0002 0x0003 0x0004	Idle Zero Calibration Started Span Calibration Started Span Set	
06	40015	Calibration Enable	W	0x0001 0x0002 0x0008 0x0009 0x000A 0x000B	Set Zero Set Span Signal simulation mode Set FP Bridge Voltage Set TP Heater Power Set IR Gain	
03	40016	Read Text 1, first char in L	R		Two Char of Gas/Units String <sup>6</sup>	
03	40017	Read Text 2	R		Two Char of Gas/Units String <sup>6</sup>	
03	40018	Read Text 3	R		Two Char of Gas/Units String <sup>6</sup>	
03	40019	Read Text 4	R		Two Char of Gas/Units String <sup>6</sup>	
03	40020	Read Text 5, last char in H	R		Two Char of Gas/Units String <sup>6</sup>	
03	40021	Text null terminator in L	R		Two Char of Gas/Units String <sup>6</sup>	

<sup>1</sup> Integer ranges from 1 all the way to 10,000.

<sup>2</sup> Units are determined by “units” field in the “notation” string

<sup>3</sup> Gas Reading times one (*x 1*) with units in notation string for “Low Range” = 0. Gas Reading times one (*x 10*) with units in notation string for “Low Range” = 1. Gas Reading times one (*x 100*) with units in notation string for “Low Range” = 2.

<sup>4</sup> Span Gas must be less than or equal to Detectable Range and is usually about ½ of it.

<sup>5</sup> Fault status bits self-reset when fault clears

<sup>6</sup> Text in ASCII, in order L byte, H byte, L byte... See field descriptions of notation string.

### Gas/Units String

Character #	1	2	3	4	5	6	7	8	9	10	11
Description	Units			0x20	Gas Type						0x00

Units – This field is ‘PPM’, ‘PPB’, or ‘\_ \_ %’ (where ‘\_ \_’ is a space, 0x20).

0x20 – The units filed is terminated with an ASCII space (0x20)

Gas Type – This field contains the gas type of the cell. Any ASCII string is permissible

0x00 – The notation string is terminated with an ASCII null character

**Table 4** Modbus™ Special Registers

REG	DM (40006 = 1)	FP (40006 = 2)	IR (40006 = 3)	TP (40006 = 4) <sup>1</sup>	PI (40006 = 5)
40011	Low Range= 0, 1, 2 0: Range >25 (0 decimal place) 1: Range 10-25 (1 decimal place) 2: Range <10 (2 decimal place)	Gas Factor (R/W) <b>Range = 79 to 565</b>	Gas Factor (R/W) <b>Range = 20 to 565</b>	Heater Power (mW) (R/W)	Low Range= 0, 1, 2 0: Range >25 1: Range 10-25 2: Range <10
40012	0x8XXX Positive Polarity Cell 0x0XXX Negative Polarity Cell 0xX000 Bias = 0mV 0xX096 Bias = 150mV 0xX0C8 Bias = 200mV 0xX12C Bias = 300mV	Cal Factor (R/W) <b>Range = 79 to 565</b>	Active Counts	Heater Voltage (mV)	0x8XXX Positive Polarity Cell 0x0XXX Negative Polarity Cell 0xX096 Bias = 0mV 0xX0C8 Bias = 150mV 0xX12C Bias = 200mV Bias = 300mV
40013	Gain Code (integer between 0 & 15)	Bridge Current (mA)	Reference Counts	Sensor Resistance (x100 Ω)	Gain Code
40014	Raw Counts 0-0xFFFF (0x8000 = nominal 0)	Bridge Voltage (mV) (Read only)	Range Divisor 1,10,100, or 1000	Heater Current (mA)	Raw Counts

<sup>1</sup> Only possible ranges are 20, 50, 100, 200. Modbus register 40001 will contain either 20, 50, 100, or 200, range divisor is not necessary.

## 5. Service and Maintenance

### 5.1 Calibration Frequency

In most applications, monthly to quarterly span calibration intervals will assure reliable detection. However, industrial environments differ. Upon initial installation and commissioning, close frequency tests should be performed, weekly to monthly. Test results should be recorded and reviewed to determine a suitable calibration interval. If, after 180 days, an AutoSpan Calibration is not performed, the ITM will generate an AutoSpan Fault.

### 5.2 Visual Inspection

The Sensor should be inspected annually. Inspect for signs of corrosion, pitting, and water damage. During visual inspection, the Splash Guard should be inspected to insure that it is not blocked. Examine the porous 316SS flame arrestor within the sensor's bottom housing for signs of physical blockage or severe corrosion. Also, inspect inside the Junction Box for signs of water accumulation or Terminal Block corrosion.

### 5.3 Condensation Prevention Packet

A moisture condensation packet should be installed in every explosion proof Junction Box. The moisture condensation prevention packet will prevent the internal volume of the J-Box from condensing and accumulating moisture due to day-night humidity changes. This packet provides a critical function and should be replaced annually. Detcon's PN is 960-202200-000.

---

**NOTE:** A desiccant cap with a desiccant packet is attached to the sensor cell housing to avoid damage during storage and shipping. This prevents water from contacting the sensor film, and as a result helps to retain the stability of the factory span calibration.

---



---

**NOTE:** Store the desiccant caps with the desiccant packets in a sealed container (i.e. zip-lock bag) for future use. It is advisable (but not mandatory) to reinstall the desiccant cap and packet during prolonged periods without power (more than 1 day is considered "prolonged"). An active desiccant packet is blue in color and turns pink when consumed. (P/N 960-399800-000 Package of 10)

---

### 5.4 Replacement of Plug-in H<sub>2</sub>S Sensor

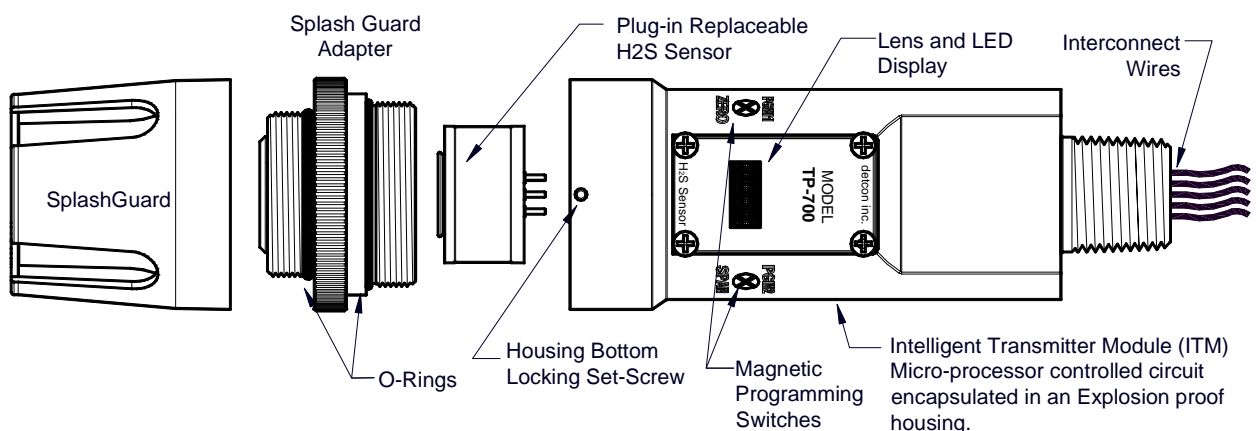

Figure 12 Sensor Assembly

a) Remove power to TP-700 sensor by lifting the + 24VDC wire in J-Box.

---

**NOTE:** It is necessary to remove power while changing the plug-in H<sub>2</sub>S sensor in order to maintain area classification.

---

b) Use a M1.5 Allen wrench to release the locking setscrew that locks the ITM and bottom housing together (One turn will suffice - Do not remove setscrew completely).

c) Remove splashguard. Unthread and remove the Bottom Housing from the ITM.

d) Gently pull the plug-in H<sub>2</sub>S sensor cell out of the ITM. Orient the new plug in sensor so that it matches with the female connector pins. It may be necessary to look from below to assure alignment is correct. When properly aligned, press the sensor in firmly to make the proper connection.

---

**NOTE:** The previous plug-in H<sub>2</sub>S sensor cell did not use a Face seal o-ring design. If you are installing this new face seal o-ring version to replace an older revision sensor, you must fully remove the adhesive gasket from the inside of bottom housing first

---

e) Thread the Bottom Housing onto the ITM to a snug fit and tighten the locking setscrew using the 1/16" Allen wrench. Reinstall the splashguard.

f) Perform "Set Heater Power (Section 3.5.6 to match the new sensor with the ITM.

g) Perform a successful AutoSpan to match the new sensor with the ITM (Section 3.4).

## 5.5 Replacement of ITM

a) Remove the power source from the sensor assembly. Disconnect all sensor wire connections at the J-Box taking note of the wire connections.

---

**NOTE:** It is necessary to remove power to the J-Box while changing the ITM in order to maintain area classification.

---

b) Use a wrench and the wrench flats provided at the top section of the ITM and unthread the ITM until it can be removed.

c) Use a M1.5 Allen wrench to release the locking setscrew that locks the ITM and bottom housing together (One turn will suffice - Do not remove setscrew completely).

d) Remove splashguard. Unthread and remove the Bottom Housing from the ITM.

e) Gently remove the plug-in H<sub>2</sub>S sensor from the old ITM and install it in the new ITM. Orient the plug-in sensor so that it matches with the female connector pins on the new ITM and press the sensor in firmly to make proper connection.

f) Thread the bottom housing onto the ITM until snug, tighten the locking setscrew and reconnect splashguard.

g) Feed the sensor assembly wires through the 3/4" female NPT mounting hole and thread the assembly into the J-box until tight and the ITM lens faces toward the front access point. Connect the sensor assembly wires inside J-Box (Refer to Section 2.6, and Figure 8).



h) Perform Set Range, Set Serial ID, Set Heater Power, Set AutoSpan Level and perform a successful AutoSpan before placing sensor assembly into operation.

## 5.6 Replacement of TP-700 Sensor Assembly

a) Remove the power source from the sensor assembly. Disconnect all sensor wire connections at the J-Box .

---

**NOTE:** It is necessary to remove power to the J-Box while changing the TP-700 sensor in order to maintain area classification.

---

b) Use a wrench and the wrench flats provided at the top section of the ITM and unthread the ITM until it can be removed.

c) Use a M1.5 Allen wrench to release the locking setscrew that locks the ITM and bottom housing together (One turn will suffice - Do not remove setscrew completely).

d) Remove splashguard. Unthread and remove the Bottom Housing from the ITM.

e) Feed the new TP-700 sensor assembly wires through the  $\frac{3}{4}$ " female NPT mounting hole and thread the assembly into the J-box until tight and the ITM lens faces toward the front access point. Connect the sensor assembly wires inside J-Box (Refer to Section 2.6, and Figure 8).

f) TP-700 sensors are factory calibrated, however, they require an initial AutoSpan calibration (section 3.4), and must be configured per customer specific application requirements.

## 5.7 Replacement of the Bottom Housing

---

**NOTE:** If the porous Flame Arrestor becomes blocked, corroded, or compromised the Bottom Housing must be replaced because the Flame Arrestor is bonded to the housing.

---

a) Remove the splashguard.

b) Use a M1.5 Allen wrench to release the locking setscrew that holds the ITM and bottom housing together (One turn will suffice - Do not remove the setscrew completely). Grab the knurled section of the bottom housing and unthread until removed.

c) Thread up the bottom housing until snug, reconnect the splashguard, and tighten the locking setscrew.

d) Re-install the splashguard.

e) It is advised to perform an AutoSpan Calibration after replacing the Bottom Housing (section 3.4 Calibration Mode (AutoSpan)).

## 6. Troubleshooting Guide

Refer to the list of Failsafe Diagnostic features listed in Section 3.6.2 for additional reference in troubleshooting activities. Listed below are some typical trouble conditions and their probable cause and resolution path.

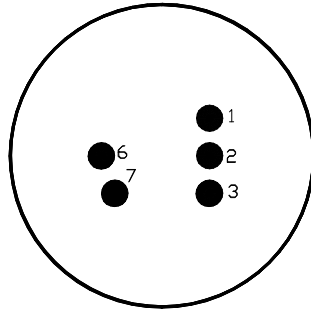

**Figure 13** Sensor PCB

### Open Heater

Probable Cause: Plug-in sensor has failed

- Remove plug-in H<sub>2</sub>S sensor and verify resistance between PIN 2 and PIN 3 (Shown in Figure 13) using an ohmmeter. At room temperature, the heater film's normal reading should range between 65 and 95 ohms.
- Replace the plug-in H<sub>2</sub>S sensor if open circuit or significantly out-of range readings are found.

### Open Sensor

Probable Cause: Plug-in sensor has failed

- Remove plug-in H<sub>2</sub>S sensor cell and verify resistance between PIN 6 and PIN 7 (Shown in Figure 13) using an ohmmeter. At room temperature, the sensor film's normal reading range should be 10-100 k-ohms. For sensors with an "X" in the serial number, the normal reading range should be 75 k-ohms to 2 meg-ohms. Failure would be open circuit.
- Replace the plug-in H<sub>2</sub>S sensor cell if an open circuit found.

### AutoSpan Calibration Faults – (Range, Stability and Clearing)

To clear any AutoSpan Calibration fault, the AutoSpan process must be completed successfully (Section 3.4).

### Range Fault

Probable Causes: Failed Sensor, Cal Gas not applied or not applied at appropriate time, problems w/ cal gas and delivery, no Humidifying Tube used, failure to properly desiccant packet the sensor cell during extended power-off periods.

- Check Heater Power Setting (should be 235 +/- 5mW at 25°C ambient temperature).
- Verify use of span gas Humidifying Tube.
- If using Splashguard with Integral Cal Port, must use Calibration Wind Guard or air movement can compromise span gas delivery.
- Check validity of span gas using H<sub>2</sub>S pull tube or other means (check MFG date on cal gas cylinder).
- Check for obstructions through stainless steel flame arrestor (including being wet, blocked, or corroded).

- Replace the plug-in H<sub>2</sub>S sensor.

### Stability Fault

Probable Causes: Failed Sensor, empty or close to empty Cal Gas Cylinder, problems with cal gas and delivery, or no Humidifying Tube used, failure to properly desiccant packet the sensor cell during extended power-off periods.

- Check Heater Power Setting (should be 235 +/- 5mW at 25°C ambient temperature).
- Verify use of span gas Humidifying Tube.
- If using Splashguard with Integral Cal Port, must use Calibration Wind Guard or air movement can compromise span gas delivery.
- Check validity of span gas using H<sub>2</sub>S pull tube or other means (check MFG date on cal gas cylinder).
- Check for obstructions through stainless steel flame arrestor (including being wet, blocked, or corroded).
- Replace the plug-in H<sub>2</sub>S sensor.

### Clearing Fault

Probable Causes: Failed Sensor, Cal Gas not removed at appropriate time or problems with cal gas and delivery, presence of background H<sub>2</sub>S, or incorrect Heater Power Setting.

- Must recover to < 5ppm in < 5 min after AutoSpan is complete
- Use bottled air (zero air) if there is a known continuous H<sub>2</sub>S background level.
- Verify use of span gas Humidifying Tube.
- Check validity of span gas using H<sub>2</sub>S pull tube or other means (check MFG date on cal cylinder).
- Check for obstructions through stainless steel flame arrestor (including being wet, blocked, or corroded).
- Perform Heater Power Setting.
- Replace the plug-in H<sub>2</sub>S sensor.

### Poor Calibration Repeatability

Probable Causes: Failed Sensor, use of wrong Cal Gas or problems w/ cal gas and delivery, or Interference Gases

- Check for adequate Sensor Life.
- Check Heater Voltage Setting (should be 235±5mW at 25°C).
- Verify use of span gas Humidifying Tube.
- Check validity of cal gas using H<sub>2</sub>S pull tube or other means (check MFG date on cal cylinder).
- Check for obstructions through stainless flame arrestor (including being wet, blocked, or corroded).
- Evaluate area for presence of any contaminating gases as listed in Section 2.3.
- Note the sensor's serial # and report repetitive problems to Detcon's Repair Department.
- Replace plug-in H<sub>2</sub>S sensor cell.

### Unstable Output/ Sudden spiking

Possible Causes: Unstable power supply, inadequate grounding, or inadequate RFI protection

- Verify Power source is stable.
- Verify field wiring is properly shielded and grounded.
- Contact Detcon to optimize shielding and grounding.
- Add Detcon's RFI Protection Circuit accessory if problem is proven RFI induced.

## Nuisance Alarms

- Check conduit for accumulated water and abnormal corrosion on terminal blocks.
- If nuisance alarms are happening at night, suspect condensation in conduit. Add or replace Detcon's Condensation Prevention Packet P/N 960-202200-000.
- Investigate the presence of other target gases that are causing cross-interference signals.
- Determine if cause is RFI induced.

## Processor and/or Memory Faults

- Recycle power in attempt to clear problem
- Restore Factory Defaults - This will clear the processor's memory and may correct problem. Remember to re-enter all customer settings for range and cal gas level after Restore Factory Defaults.
- If problem persists, replace the Intelligent Sensor Module.

## Unreadable Display

- If due to excessive sunlight, install a sunshade to reduce glare.

## Nothing Displayed – Transmitter not Responding

- Verify conduit has no accumulated water or abnormal corrosion.
- Verify required DC power is applied to correct terminals.
- Swap with a known-good ITM to determine if ITM is faulty.

## Faulty 4-20mA Output

If Sensor has a normal reading with no Faults displayed, and the 4-20 mA signal output is 0mA....

- Check that wiring is properly connected at terminal blocks and through to controller inputs.
- The 4-20mA output loop must be closed to avoid a Loop Fault. If the 4-20mA output is not being used the green wire from the sensor must be connected to the (-) terminal on the Transient Protection Module to ensure that it does not create a 4-20mA Fault. (section 2.6 Field Wiring)
- Perform a "Signal Output Check" sequence via Section 3.5.7 and verify 4-20mA output with Current Meter.
- Swap with new ITM to determine if the ITM's 4-20mA output circuit is faulty.
- If the 4-20mA current loop is still out of tolerance, contact Detcon at [Service@detcon.com](mailto:Service@detcon.com), or contact Detcon customer service.

## No Communication - RS-485 Modbus™

If sensor has a normal reading with no Faults displayed and the Modbus™ is not communicating....

- Verify that the correct (and non-duplicated) serial address is entered (per Section 0).
- Check that the wiring is properly connected at terminal blocks, and the serial loop is wired correctly.
- Perform a "Signal Output Check" per Section 3.5.7 and troubleshoot wiring.
- Consider adding a Modbus™ repeater if the distance from the nearest distribution drop is excessive.
- Swap with new ITM to determine if the ITM's serial output circuit is faulty.
- Refer to Detcon's "Guide to Proper Modbus™ Communications" Application Note.

## 7. Customer Support and Service Policy

Detcon Headquarters

Shipping Address: 4055 Technology Forest Blvd., The Woodlands Texas 77381

Mailing Address: P.O. Box 8067, The Woodlands Texas 77387-8067

Phone: 888.367.4286, or 281.367.4100

Fax: 281.292.2860

- [www.detcon.com](http://www.detcon.com)
- [service@detcon.com](mailto:service@detcon.com)
- [sales@detcon.com](mailto:sales@detcon.com)

All Technical Service and Repair activities should be handled by the Detcon Service Department via phone, fax or email at contact information given above. RMA numbers should be obtained from the Detcon Service Department prior to equipment being returned. For on-line technical service, customers should have ready the model number, part number, and serial number of product(s) in question.

All Sales activities (including spare parts purchase) should be handled by the Detcon Sales Department via phone, fax or email at contact information given above.

### 7.1 Warranty Notice

Detcon Inc. warrants the Model TP-700 H<sub>2</sub>S gas sensor to be free from defects in workmanship of material under normal use and service for two years from the date of shipment on the ITM electronics and for a 10 year conditional period on the plug-in H<sub>2</sub>S sensor. See Warranty details in section 8 TP-700 Sensor Warranty.

Detcon Inc. will repair or replace without charge any such equipment found to be defective during the warranty period. Full determination of the nature of, and responsibility for, defective or damaged equipment will be made by Detcon Inc. personnel.

Defective or damaged equipment must be shipped to the Detcon Inc. factory or representative from which the original shipment was made. In all cases this warranty is limited to the cost of the equipment supplied by Detcon Inc. The customer will assume all liability for the misuse of this equipment by its employees or other contracted personnel.

All warranties are contingent upon the proper use in the application for which the product was intended and does not cover products which have been modified or repaired without Detcon Inc. approval, or which have been subjected to neglect, accident, improper installation or application, or on which the original identification marks have been removed or altered.

Except for the express warranty stated above, Detcon Inc. disclaims all warranties with regard to the products sold. Including all implied warranties of merchantability and fitness and the express warranties stated herein are in lieu of all obligations or liabilities on the part of Detcon Inc. for damages including, but not limited to, consequential damages arising out of, or in connection with, the performance of the product.

## 8. TP-700 Sensor Warranty

### 8.1 Plug-in H<sub>2</sub>S Sensor Warranty

Detcon Inc. warrants, under normal intended use, each new plug-in H<sub>2</sub>S sensor (PN 370-010000-700) for a ten year period under the conditions described as follows: The warranty period begins on the date of shipment to the original purchaser and ends ten years thereafter. The sensor element is warranted to be free of defects in material and workmanship. Should any sensor fail to perform in accordance with published specifications within the warranty period, return the defective part to Detcon, Inc., 4055 Technology Forest Blvd., The Woodlands, Texas 77381, for necessary repairs or replacement.

First 5 years	\$35.00 handling charge
6th year	\$78.00 handling charge
7th year	\$121.00 handling charge
8th year	\$164.00 handling charge
9th year	\$208.00 handling charge
10th year	\$251.00 handling charge
Non-warranty	\$295.00 charge

---

**NOTE:** The warranty will not be honored if evidence shows that the sensor cell was damaged by moisture exposure due to improper handling and protection during periods of removed power or storage. The sensor cell must be protected during periods of removed power or storage by use of a Dust Cap (P/N 602-003306-0TP) and a Desiccant Packet (P/N 960-240010-000).

---

#### Terms & Conditions

- The original serial number must be legible on each sensor element base.
- Shipping point is FOB the Detcon factory.
- Net payment is due within 30 days of invoice.
- Detcon, Inc. reserves the right to refund the original purchase price in lieu of sensor replacement.

### 8.2 ITM Electronics Warranty

Detcon Inc. warrants, under intended normal use, each new Model 700 ITM to be free from defects in material and workmanship for a period of two years from the date of shipment to the original purchaser. All warranties and service policies are FOB the Detcon facility located in The Woodlands, Texas.

### 8.3 Terms & Conditions

- The original serial number must be legible on each ITM.
- Shipping point is FOB the Detcon factory.
- Net payment is due within 30 days of invoice.
- Detcon, Inc. reserves the right to refund the original purchase price in lieu of ITM replacement.

## 9. Appendix

### 9.1 Specifications

Sensor Type:	Continuous diffusion/adsorption type CHEMFET Solid State MOS type True plug-in replaceable type
Sensor Life:	5-10 years typical
Measuring Ranges:	0-20ppm, 0-50ppm, 0-100ppm
Accuracy/ Repeatability:	± 10% of reading or ± 2ppm (whichever is greater)
Response Time:	T50 < 30 seconds, T80 < 60 seconds
Outputs	Linear 4-20mA DC RS-485 Modbus™ RTU
Electrical Classification:	Explosion Proof CSA and US (NRTL) Class I, Division 1, Groups B, C, D (Tamb=-40° to 75°C) Class I, Zone I, Group IIB+H2  ATEX EEx d IIB+H <sub>2</sub> T4 (Tamb=-40° tp 75°C)
Ingress Protection	NEMA 4X, IP66
Safety Approvals:	cCSAus Complies with ISA92.0.01 Part 1-1998; Performance Requirements for H <sub>2</sub> S ATEX CE Marking SIL2 FMEDA Rating
Warranty:	Sensor – 10 year conditional Transmitter – 2 years

### Environmental Specifications

Operating Temperature:	-40°F to +167°F; -40°C to +75°C FM ISA 92.0.01 Certified from -40°C to +65°C for H <sub>2</sub> S
Storage Temperature:	-31°F to +131°F; -35°C to +55°C
Operating Humidity:	5-100% RH (Non-condensing)
Operating Pressure Range:	Atmospheric ± 10%

### Mechanical Specifications

Dimensions	7"H x 2.2" Dia.; 178mmH x 65mm Dia. (sensor assembly only)
------------	--

11"H x 6.1"W x 3.75"D; 280mmH x 155mmW x 96mmD (with junction box)  
Mounting holes (J-box) 5.5"; 140mm center to center

Weight: 2 lbs; 0.907kg (sensor only)  
6 lbs; 2.72kg (w/aluminum j-box)  
9 lbs; 4.08kg (w/stainless steel j-box)

### Electrical Specifications

Input Voltage: 11-30 VDC

Power Consumption: Normal operation = 68mA (<1.7 watt)  
Maximum = 85mA (2 watts)

Inrush current: 1.0A @ 24V

RFI/EMI Protection: Complies with EN61000

Analog Output: Linear 4-20mA DC current (1000 ohms maximum loop load @ 24VDC)  
0mA All Fault Diagnostics  
2mA In-Calibration  
4-20mA 0-100% full-scale  
22mA Over-range condition

Serial Output: RS-485 Modbus™ RTU

Baud Rate: 9600 BPS (9600,N,8,1 Half Duplex)

Status Indicators: 4-digit LED Display with gas concentration  
full-script menu prompts for AutoSpan,  
Set-up Options, and Fault Reporting

Faults Monitored: Heater, Loop, Input Voltage, Sensor, Processor, Memory, Calibration

Cable Requirements: Power/Analog: 3-wire shielded cable  
Maximum distance is 13,300 feet with 14 AWG  
  
Serial Output: 2-wire twisted-pair shielded cable specified for RS-485 use  
Maximum distance is 4,000 feet to last sensor

I/O Protection: Over-Voltage, Miss-wiring, EMI/RFI Immunity



## 9.2 Spare Parts, Sensor Accessories, Calibration Equipment

Part Number	Spare Parts
927-015500-100	TP-700 Intelligent Sensor Module (ITM)
602-003280-000	TP 700 Housing Bottom Assembly (includes Flame Arrestor)
370-010000-700	Replacement Plug-in H <sub>2</sub> S sensor
500-003087-100	Transient Protection PCA
602-003306-0TP	Dust Cap 1.5" Thread with Desiccant Pack
960-202200-000	Condensation Prevention Packet (for J-Box replace annually)
960-240010-000	Desiccant Protection Packet for Cell
<b>Sensor Accessories</b>	
897-850800-010	NEMA 7 Aluminum Enclosure less cover – 3 port
897-850400-010	NEMA 7 Aluminum Enclosure Cover (Blank)
897-850801-316	NEMA 7 316SS Enclosure less cover – 3 port
897-850401-316	NEMA 7 316SS Enclosure Cover (Blank)
613-120000-700	Sensor Splashguard with integral Cal-Port
602-003306-0TP	Dust Cap 1.5" Thread with Desiccant Pack
943-002273-000	Hazardous location dust guard
327-000000-000	Programming Magnet
960-202200-000	Condensation Prevention Packet (for J-Box replace annually)
960-240010-000	Desiccant Protection Packet for Cell
<b>Calibration Accessories</b>	
943-000000-000	Calibration Wind Guard
985-241100-321	In-Line Humidifying Tube
943-000006-132	Threaded Calibration Adapter
943-020000-000	Span Gas Kit: Includes calibration adapter, In-Line Humidifying Tube, 200cc/min fixed flow regulator, and carrying case. (Does Not include gas).
942-010112-010	Span Gas cylinder: 10ppm H <sub>2</sub> S in air (for 20ppm range) Contains 58 liters of gas and is good for 80 calibrations
942-010112-025	Span Gas cylinder: 25ppm H <sub>2</sub> S in air (for 50 and 100ppm ranges). Contains 58 liters of gas and is good for 80 calibrations
943-090005-502	200cc/min Fixed Flow Regulator for span gas bottle
943-000GMI-CAP	TP-700 Adapter Cover used with General Monitors glass ampoule breaking cup.
<b>Recommend Spare Parts for 2 Years</b>	
927-015500-100	TP-700 Intelligent Sensor Module (ITM)
602-003280-000	Housing Bottom Assembly (includes Flame Arrestor)
370-010000-700	Replacement Plug-in H <sub>2</sub> S sensor
500-003087-100	Transient Protection PCA
960-202200-000	Condensation prevention packet (for J-Box replace annually)

### 9.3 Model TP-700 Engineering Drawings

- 1) TP-700 Series Breakaway and Wiring
- 2) TP-700 Series Wiring and Dimensional, 316 SS conduit
- 3) TP-700 Series Wiring and Dimensional, Aluminum conduit

## 10. Revision Log

Revision	Date	Changes made	Approval
2.3	12/16/2008	Previous revision.	N/A
2.4	04/25/2011	Removed Teflon note in Section 2.5. Added Revision Log Section 10.	LU
2.5	07/11/2011	Added inrush current information to Specifications section. Addend wiring and dimensional drawing for aluminum conduit	LU
2.6	04/16/2012	Changed the use of cable type, made changes to the Modbus Register Map.	LU
2.7	08/07/2012	Updated spare parts list, corrected specifications	BM
2.8	01/07/2013	Updated ATEX approvals label, updated EN standards that sensor assembly meets. Updated ATEX listing in Specifications	BM
2.9	04/02/2013	Updated ATEX installation instructions regarding use of ring terminal for earth ground using screw and lock-washer. Updated guidelines for metric special fasteners used in 700 assembly	BM
3.0	10/25/13	Updated for 4-20mA errors	LU
3.1	11/20/13	Correct Modbus™ Register Map	LU
3.2	12/19/13	Update Calibration to include Wind Guard	BM
3.3	02/28/14	Update 4-20mA wiring, and specifications	BM
3.4	03/07/14	Add notation on use of desiccant pack with sensor cell	BM
3.5	08/07/14	Updated Calibration Section	BM

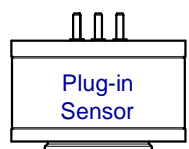
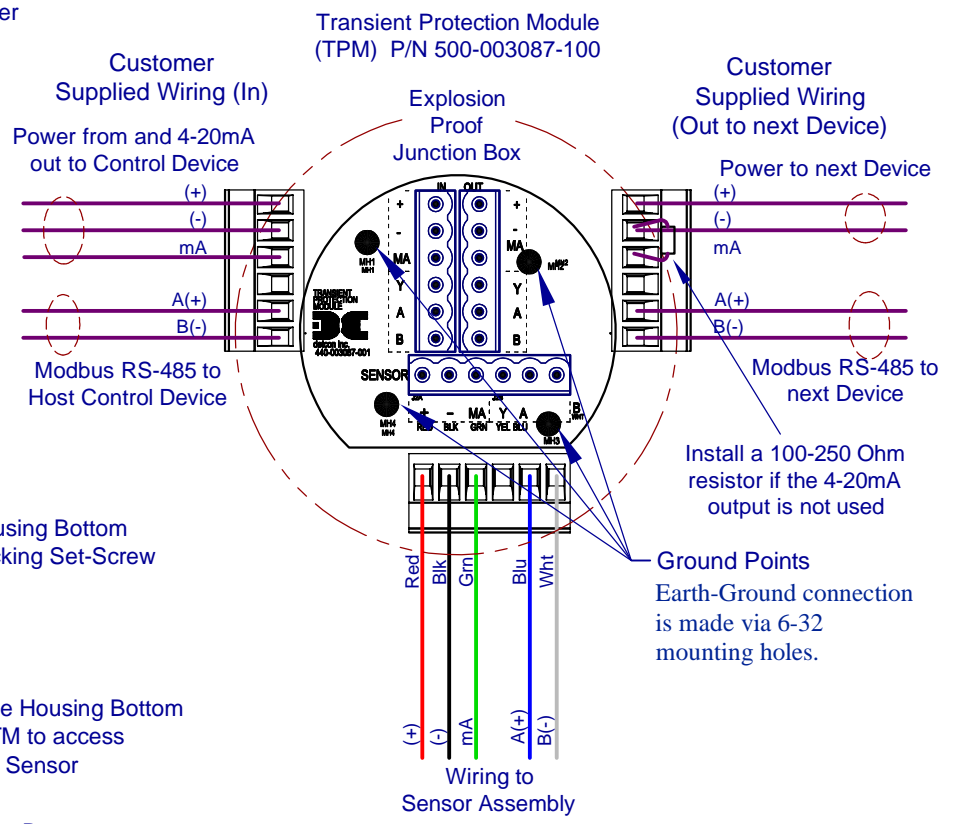
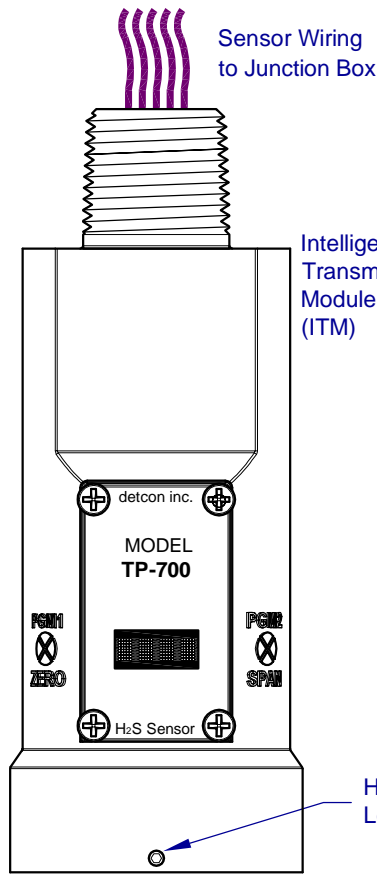

Remove Housing Bottom from ITM to access Plug-in Sensor

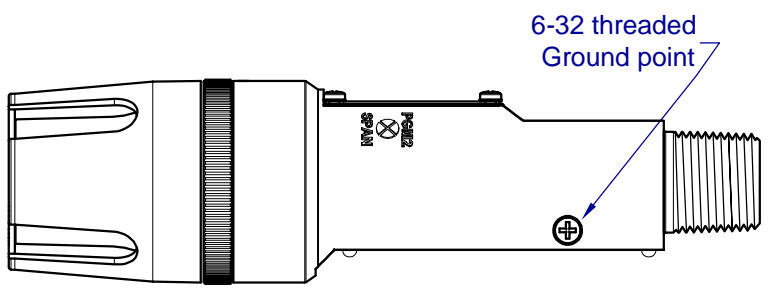
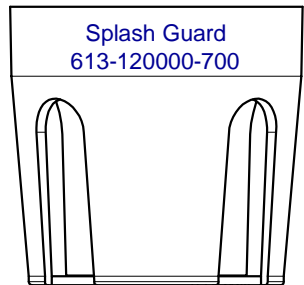
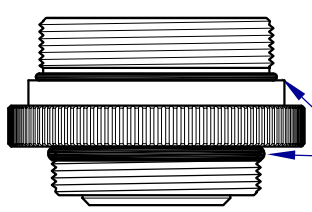

**NOTES:**

P.O. NO.	NA	The information and technical data disclosed by this document may be used and disseminated only for the purposes and to the extent specifically authorized by Detcon Incorporated in writing. Such information and technical data are proprietary to Detcon Incorporated and may not be used or disseminated except as provided in the foregoing sentence.
REQ. NO.	NA	
PROJECT NO.	NA	
SERIAL NO.	NA	
PLANT:	NA	

REV	DATE	DESCRIPTION	DRN	CHKD	APPD	DWG #	SUBJECT
6	10/25/13	Change Splashguard and Housing	RH	SF	BM	3168	Updates
5	06/25/10	Add drawing for Aluminum Conduit	RH	SF	BM	3168	Updates
4	01/14/08	Removed yellow wire	RH	SF	BM	3168	Updates
3	04/01/07	TPM Changed	RH	EM	BM	3168	Updates
2	11/28/06	Correct pinout on TPM	RH	EM	BM	3168	Updates

**DETCON INC.**  
3200 Research Forest Dr. A-1 \* The Woodlands Texas 77381 \* www.detcon.com

CLIENT: NA

PROJECT: NA

DRAWN BY: R HUTSKO

FIRST ISSUE: 03/30/06

SCALE: NTS

SHEET NUM: NA

SHEET REV: A

SALES ORDER NO. NA

DRAWING NO. 3150-1

SIZE: A

REV: 6

REVISION HISTORY

REF. DWGS

This page left intentionally blank

Shipping Address: 4055 Technology Forest Blvd., The Woodlands Texas 77381  
Mailing Address: P.O. Box 8067, The Woodlands Texas 77387-8067  
Phone: 888.367.4286, 281.367.4100 • Fax: 281.292.2860 • [www.detcon.com](http://www.detcon.com) • [sales@detcon.com](mailto:sales@detcon.com)

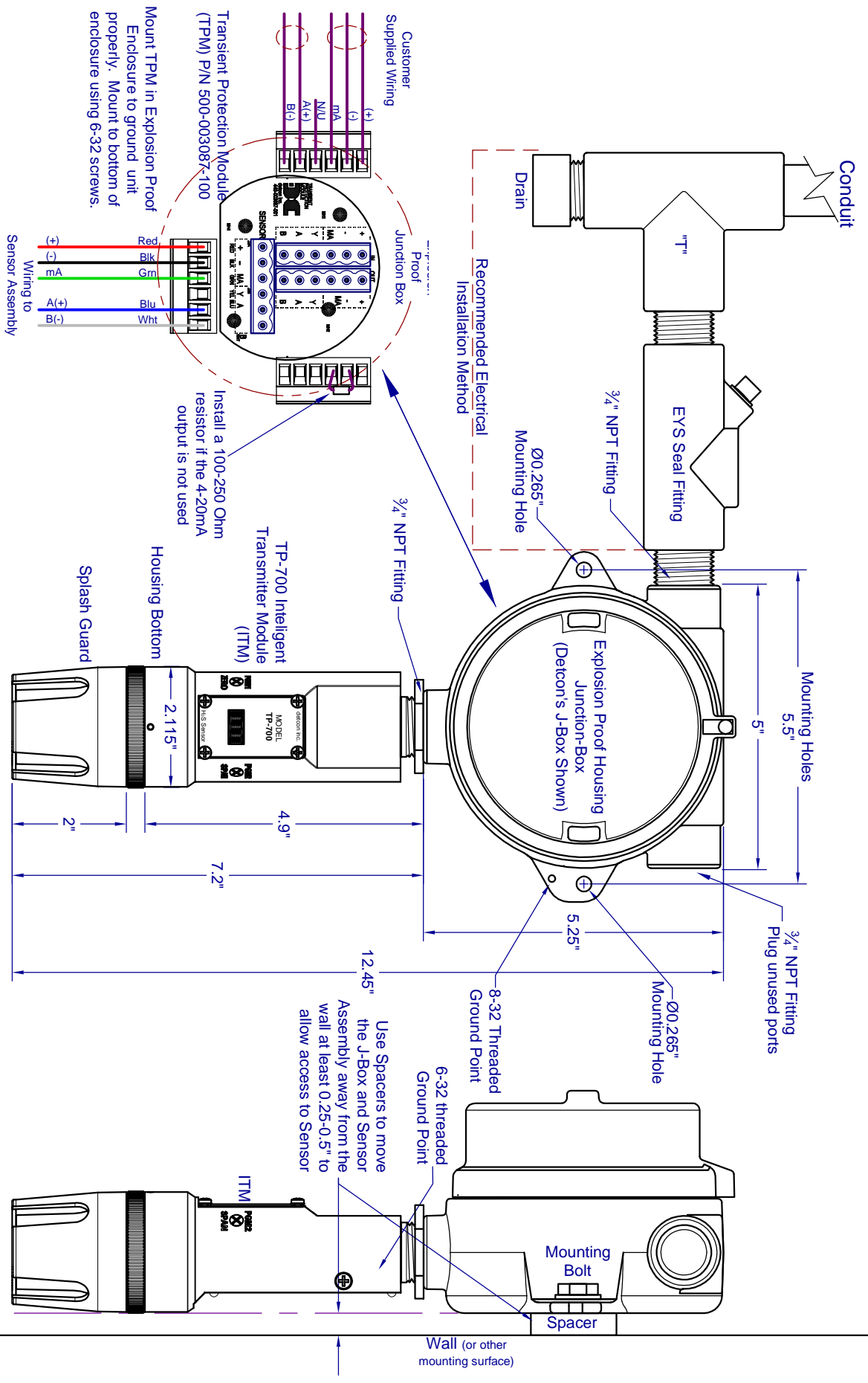

Mount TPM in Explosion Proof Enclosure to ground unit properly. Mount to bottom of enclosure using 6-32 screws.

Wiring to Sensor Assembly

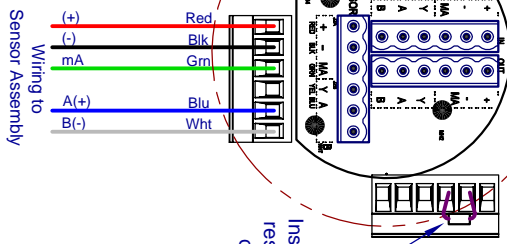

Install a 100-250 Ohm resistor if the 4-20mA output is not used

**NOTES:**

If the Sensor is not mechanically grounded to the Junction Box, and external ground strap should be used to insure proper grounding.

PO. NO.	NA	The information and technical data disclosed by this document may be used and disseminated only for the purposes and to the extent specifically authorized by Detcon Incorporated and may not be used or disseminated in the foregoing sentence.
REQ. NO.	NA	
PROJECT NO.	NA	
SERIAL NO.	NA	
PLANT	NA	

REV.	DATE	DISPOSITION	DRN	CHKD	APPD
1	10/25/13	Change Shroud and Housing	RH	SF	BM
2	06/25/10	Add drawing for Aluminum Coupler	RH	SF	BM
3	01/14/08	Removed yellow wire	RH	SF	BM
4	04/01/07	TPM Changed	RH	EM	BM
5	11/28/06	Correct print on TPM	RH	EM	BM

REVISION HISTORY		REF. DWGS	
PROJECT:	NA	TP-700 Series	Wiring, Dimensional, and Mounting
DESIGNER:	R. Huisko	SCALE:	NTS
DRAWN BY:	NTS	SIZES ORDER NO.:	NA
CHECKED BY:	NTS	DRAWING NO.:	3150-2
DATE:	03/30/06	SHEET NO.:	NA
		SIZE:	A
		REV:	6

**DETCON INC.**  
 3300 Research Forest Dr. A-1 • The Woodlands, Texas 77381 • www.detcon.com

This page left intentionally blank

Shipping Address: 4055 Technology Forest Blvd., The Woodlands Texas 77381  
Mailing Address: P.O. Box 8067, The Woodlands Texas 77387-8067  
Phone: 888.367.4286, 281.367.4100 • Fax: 281.292.2860 • [www.detcon.com](http://www.detcon.com) • [sales@detcon.com](mailto:sales@detcon.com)

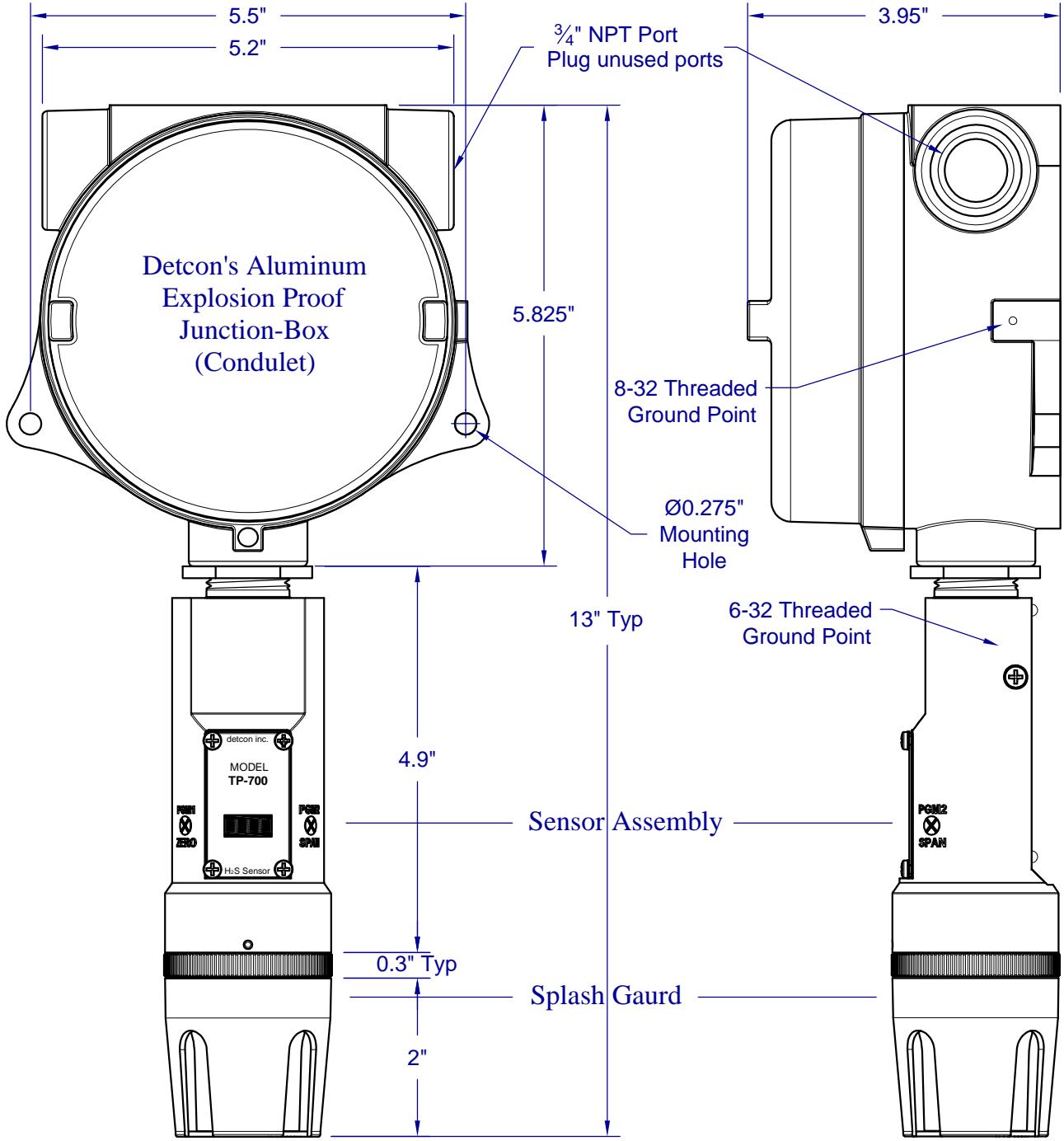

**NOTES:**

P.O. NO.	NA	The information and technical data disclosed by this document may be used and disseminated only for the purposes and to the extent specifically authorized by Detcon Incorporated in writing. Such information and technical data are proprietary to Detcon Incorporated and may not be used or disseminated except as provided in the foregoing sentence.
REQ. NO.	NA	
PROJECT NO.	NA	
SERIAL NO.	NA	
PLANT:	NA	

REV	DATE	DESCRIPTION	DRN	CHKD	APPD	DWG #	SUBJECT
6	10/25/13	Change Splashguard and Housing	RH	SF	BM	3168	Updates
5	06/25/10	Add drawing for Aluminum Condulet	RH	SF	BM	3168	Updates
4	01/14/08	Removed yellow wire	RH	SF	BM	3168	Updates
3	04/01/07	TPM Changed	RH	EM	BM	3168	Updates
2	11/28/06	Correct pinout on TPM	RH	EM	BM	3168	Updates

		<b>DETCON INC.</b> <small>3200 Research Forest Dr. A-1 * The Woodlands Texas 77381 * www.detcon.com</small>	
CLIENT:	NA	FP-700 Series with Detcon Aluminum Junction-Box	
PROJECT:	NA	SCALE	SALES ORDER NO.
DRAWN BY:	R HUTSKO	NTS	NA
FIRST ISSUE:	06/25/10	SHEET NUM.	NA
REF. DWGS		SIZE	REV
		A	6

This page left intentionally blank

Shipping Address: 4055 Technology Forest Blvd., The Woodlands Texas 77381  
Mailing Address: P.O. Box 8067, The Woodlands Texas 77387-8067  
Phone: 888.367.4286, 281.367.4100 • Fax: 281.292.2860 • [www.detcon.com](http://www.detcon.com) • [sales@detcon.com](mailto:sales@detcon.com)